

# The Influence of Intellectual Capital to Architect's Work Performance Through Leadership and Motivation in Malang City-Indonesia

Breeze A. S. Maringka<sup>1</sup>, Anwar Sanusi<sup>2</sup>, Abdul Manan<sup>3</sup>

<sup>1</sup>Doctoral Program of Economics, University of Merdeka Malang, East Java, Indonesia-65416

<sup>2,3</sup>Faculty of Economics and Business, University of Merdeka Malang, East Java, Indonesia-654146

**Abstract**— This study has a purpose to describe the intellectual capital, leadership, motivation and workperformance owned by architects, and create certain analysis about: the influence of intellectual capital on leadership, the influence of intellectual capital on motivation, the influence of intellectual capital on architect's workperformance, the influence of leadership on architect's workperformance, the influence of motivation on architect's workperformance, the influence of intellectual capital on architect's workperformance through leadership, and the influence of intellectual capital on architect's workperformance through motivation. The population of this study were architects in Malang area who are members of Ikatan Arsitek Indonesia (IAI) as the professional association of architects, Ikatan Arsitek Indonesia from Malang area with 186 architects taken as samples by census. The analysis technique for this study were descriptive analysis and quantitative analysis. From the analysis result it showed that leadership mediates the influence of intellectual capital on architect's workperformance which means that intellectual capital can improve workperformance when leadership implementation carried out in a good way.

**Keywords**— Intellectual capital, Architect's work performance, Leadership.

## I. INTRODUCTION

The world economy globalization fosters the increase of architect services and business sector development in Indonesia. The development in the field of construction services creates a higher intensity of competition between companies and architects. With the existence of competition brings fact of the need to have a competitive edge or competitive advantage over the other company. One way to have competitiveness is lies on architects through improvement of their work performance. In this study, architect's work performance will be put as primary focus because architects are the conceptor of any planning/development idea. In Indonesia, Architects have a unifying platform of *Ikatan Arsitek Indonesia/ IAI* (Indonesian Architects Association) as stated in Republic of Indonesia Law No.6 of 2017 concerning Architects. This law also regulates the duties and responsibilities of architects together with their rights. *Ikatan Arsitek Indonesia* has administrators in each province and certain cities/regencies, including in Malang where the management for the Malang Region is covering Malang City, Malang Regency and Batu City (*Malang Raya*).

Technological innovation and intense business competition these days push consulting firms and architects to change the way they do business. To keep their competitive edge, consulting firms and architects must make a quick change in their strategies from original idea that prioritizes labor (a labor-based business) that get mixed with implementation steps into a knowledge-based business development that prioritizes solely on specific feature as a designer architect or planner, thus make its main characteristic more to a science.

In the present day where intangible assets have become a source of wealth and company progress, intellectual capital may be one of the "missing links" (Young et al., 2009). It is

considered as hidden value of an organization. There are three components of Intellectual Capital (human capital, organizational capital, customer capital) which aimed to measure any intangible assets and to re-assess the knowledge that applied to improve business excellence.

The Intellectual Capital concept has received great attention from various communities especially accountants. This phenomenon requires accountants to seek more detailed information about matters relating to the management of Intellectual Capital, starts from how to make identification, measurement until making an exposure in the company's annual report.

Nevertheless, researches on Intellectual Capital are still inconsistent especially in relation to company performance. Firer and William (2003) stated that physical capital is the most significant factor that affects company performance, thus there is no positive influence between intellectual capital and company performance. However, Houari et al. (2014) stated that there is a relationship between intellectual capital and the leadership process. Darmayanti et al. (2014) also stated that intellectual competence and work motivation have a positive and significant effect on work performance.

## II. LITERATURE REVIEW

### A. Work Performance

According to Pasolong (2008: 197), the concept of work performance can basically be seen from two aspects of employee work performance (per-individual) and organizational work performance. Employee work performance is the result of individual work in an organization; meanwhile, organizational work performance is the totality of the work achieved by an organization. Employee work performance and organizational work performance are very closely related. The success of achieving

organizational goals cannot be separated from the resources owned by the organization that are driven or run by employees that took active role as actors in achieving the organization goals (Pasolong, 2008: 57). Furthermore, as stated by Keban (2004: 192) work performance of an organization is visible from the level to which the organization can achieve its goals based on the vision and mission that has been previously set. In line with this statement, Mahsun (2006: 25) said that work performance is a description of the level of implementation of an activity or program or policy in realizing the goals, objectives, mission and vision of the organization as stated in the strategic planning of an organization. Organizational work performance or company work performance is an indicator of the achievement level that can be attained and reflects the success of a manager or entrepreneur. Work performance in an organization is an inseparable element while carrying out the organizational tasks, both in government and private institutions.

### B. Intellectual Capital

According to some experts, the definition of intellectual capital is as follows: Itami (1987) defines intellectual capital as an intangible asset which includes technology, customer information, brand name, reputation, and organizational culture which are very valuable for a company's competitive advantage. As an addition to it, Edvinsson (1997) states that intellectual capital are applied experience, organizational technology, customer relations, and expertise that can create a firm's competitive advantage. While, The Organization for Economic Co-Operation and Development (OECD, 1999) describes intellectual capital as the economic value of two categories of a company's intangible assets: Organizational (structural) capital and Human capital. Structural capital includes proprietary software and systems, distribution networks, and supply chains. Human capital includes human resources from inside or outside organization such as customers and suppliers.

### C. Leadership

Leadership inside an organization plays crucial role to determine the accomplishment (success) or failure of an organization, or in other word, organization and the leader are responsible when there is a failure of a job. A leader must be able to coordinate and instruct employees who have different feelings and minds and are of various types and characteristics, so the problem of leadership can't be seen as an easy task. The ability of a leader can facilitate company to meet its demand which is depending on the skills and abilities of the leader. Leadership according to Terry (1972: 458): is an activity to influence people so that they can be directed to achieve organizational goals.

In addition, leadership is the ability to provide direction and coordination to subordinates (organizational members) in achieving organizational goals, as well as a willingness to be the main person in charge of the group activities they lead (Hanafi, 2011).

### D. Motivation

According to Maslow (1943), motivation is the strength (energy) of a person that can lead to persistence and enthusiasm in carrying out an activity, both from within the individual himself (intrinsic motivation) and from outside the individual (extrinsic motivation). For this reason, it is necessary to make a description of; basic human needs, the theoretical framework of motivation, measurement of motivation, factors that influence motivation, and opinion differences among experts about motivation.

## III. METHOD

### A. The Definition of Operational Variabel's

#### 1. Architect work performance

Architect work performance is architect's work in the form of an architectural design document. The indicators are; concept design, pre-design, design development, drawing work, procurement of construction implementers and periodically supervision.

#### 2. Intellectual capital

Intellectual Capital is a thinking ability and knowledge resources in the form of employees, customers, processes or technology that implemented in the process of creating value for architects. The indicators are; human capital, customer capital, and structural capital.

#### 3. Leadership

Leadership is the ability to provide direction and coordination to subordinates (organizational members) in achieving organizational goals, as well as a willingness to be the main person who responsible of the group activities that this person lead. The indicators are; able to be fair, able to provide advice, able to support goals, play as catalysts, able to create secure environment or feelings, able to be the representative of organizations, play as sources of inspiration and able to value opinions among employees.

#### 4. Motivation

Motivation is the driving force that creates a more intensive work enthusiasm for employees. The indicators are: appropriate salary, job security, honor and recognition, fair treatment, an interesting working atmosphere along with an attractive position in the company.

### B. Population and Sample of the Study

The population of this study were architects in Malang area who are members of the Ikatan Arsitek Indonesia (professional association of architects) for Malang area with 186 architects as the sample of this study. A census was chosen as the sampling technique.

### C. Data Analysis Technique

The analysis techniques applied in this study were descriptive analysis technique and quantitative analysis technique. Descriptive analysis technique was used to determine the respondent's characteristics which measured from a number of indicators stated in the questionnaire, while the Quantitative analysis technique was carried out through Structural Equation Modeling (SEM).

IV. RESULT

A. Result of the Study

1. Normally test

From the results of data processing, the CR multivariate value of 1.212 lies between -2.58 to 2.58, which can be concluded that the assumption of multivariate normality has been fulfilled, thus the normality assumption required by SEM analysis was achieved.

2. Outlier test

The result of outlier test by Mahalanobis Distance Squared method showed that the observed variable has a detected Mahalanobis Distance Observed Variable value smaller than the chi square table (df = 23, α = 0.001) namely 49.25. Based on the results of the analysis, it is known that the 23 indicators used in this study have a Mahalanobis distance squared values smaller than 49.25, so none of them contain outliers.

3. Multicollinearity and singularity test

Based on the SEM output analyzed by AMOS showed that the determinant of the sample covariance matrix has a result of 0.224 which means that the value is greater than zero, so there is no multicollinearity or singularity occur in this study, therefore this data is feasible to use.

B. Result of SEM Analysis

In accordance with the literature review and study objectives, an overall structural model was developed as follows:

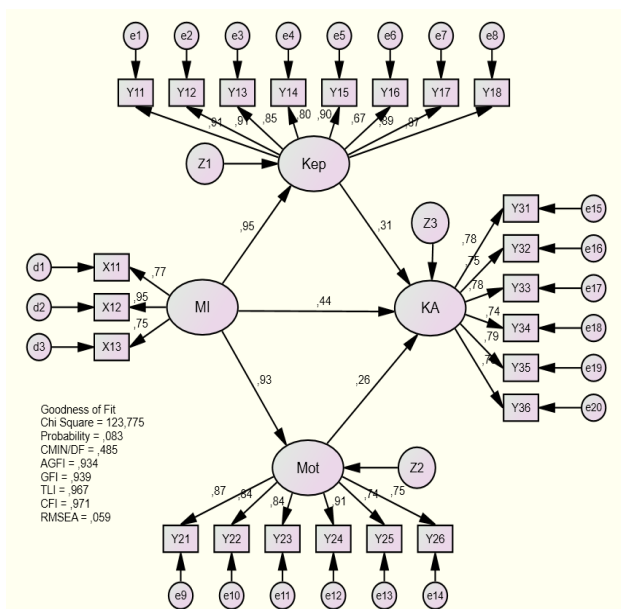

Fig. 1. Result of SEM analysis

According to AMOS 18 computation for this SEM model, the goodness of fit indices is presented in Table 1. Then, the index values are compared with the critical value (cut-off value) of each index. A good model is expected to have goodness of fit indices that are greater than or equal to the critical value.

TABLE 1. The Result of Goodness of Fit for Modified Structural Model

Goodness Of Fit Index	Cut-off Value	Model Result	Category
Chi-Square (df = 225)	124,34	123,775	Good
Probability Chi-Square	≥ 0,05	0,083	Good
CMIN/DF	≤ 2,00	0,485	Good
RMSEA	≤ 0,08	0,059	Good
GFI	≥ 0,90	0,939	Good
AGFI	≥ 0,90	0,934	Good
CFI	≥ 0,95	0,967	Good
TLI	≥ 0,95	0,971	Good

Source : Primary Data Tabulation

Based on the evaluation results of Goodness of Fit Indices criteria displayed in Table 1 showed that the evaluation of the overall model has met the criteria, thus the model can be accepted.

C. Result of Hypothesis Test

Hypothesis testing in this study was carried out by assessing the p value (probability), if the p value is higher or equal to 0.05, then it is said there is a significant influence to the matter.

TABLE 2. The Hypothesis Test

Hip	Variables			Regression Coefficients			Result	
	Exogen	Mediation	Endogen	Direct Effect Koef.	Indirect Effect Prob.	Total		
H <sub>1</sub>	Intellectual Capital	Leadership	-	0,95	0,00*	-	0,95	Accepted
H <sub>2</sub>	Intellectual Capital	Motivation	-	0,93	0,000*	-	0,93	Accepted
H <sub>3</sub>	Intellectual Capital	-	Architect Work performance	0,44	0,042*	-	0,44	Accepted
H <sub>4</sub>	-	Leadership	Architect Work performance	0,31	0,047*	-	0,47	Accepted
H <sub>5</sub>	-	Motivation	Architect Work performance	0,26	0,023*	-	0,47	Accepted
H <sub>6</sub>	Intellectual Capital	Leadership	Architect Work performance	0,44	0,042*	0,29	0,73	Accepted
H <sub>7</sub>	Intellectual Capital	Motivation	Architect Work performance	0,44	0,042*	0,25	0,69	Accepted

\* significant at α 5%.

V. DISCUSSION

A. The Description of Intellectual Modal, Leadership, Motivation, and Work Performance of Architect's

The concept of Intellectual Capital is formed by human capital, structural capital and customer capital. The biggest contribution to the formation of intellectual capital is human capital, which is described as working state at full capacity. This shows that people are valuable assets in achieving the pre-determined goals. It is aligned with Stewart's (1997) conception which stated that intellectual capital is a material that has been formulated, caged, and leveraged to create wealth by producing high valuable assets.

Leadership is formed by acts of fairness, giving suggestions, supporting goals, catalysts, creating of security, representing of work teams, sources of inspiration and respect of others. The biggest contribution to the formation of leadership is supporting goals, as reflected in the ability of respondent to communicate fluently with the work team. This is in accordance with the conception of Terry (1972: 458) which states that leadership is an activity to influence people so that it can be directed to achieve organizational goals.

Motivation is formed from a suitable salary, job security, respect and recognition, fair treatment, interesting working atmosphere and attractive position. The biggest contribution to

the formation of motivation is an interesting work atmosphere, reflected in the respondent who is willing to work according to the agreed plan. This is consistent with Maslow's (1943) conception which states that a person's strength (energy) can generate persistence and enthusiasm in carrying out an activity, both those originating from within the individual himself (intrinsic motivation) and from outside the individual (extrinsic motivation).

As the last concept, architect work performance is formed from the concept of design, pre-design, design development, drawing work, procurement of construction implementers, and periodically supervision. The biggest contribution to the formation of architect's performance is the design concept which is reflected in the respondent's sketching of ideas. This is in line with the conception of Brumbach (1988) which states that work performance is a behavior and outcome. The behavior that comes from the individual, starting with abstract to action that resulted in the task completion as assigned.

#### *B. The Influence of Intellectual Capital on Leadership*

Intellectual capital creates influence to leadership, which means that the more intellectual capital the better the improvement to leadership. Intellectual capital is knowledge and information which applied in work to create value. Intellectual capital can be viewed as knowledge in the formation of intellectual property and every experience which can be used too in creating wealth. Intellectual capital is covered all the architect's knowledge, organization and abilities to create added value and resulted in having a sustainable competitive edge/advantage. Intellectual capital is a resource that is owned by an architect which later can provide benefits in the future, as seen from the leadership. The indicator of intellectual capital which provides the greatest contribution in improving the quality of leadership derived from customer capital, reflected in every job accepted that will be assumed by the architects as the highest trust given. Customer capital is created by mutual understanding between consumer (customer) needs and producer (architect) in consistency. The result of this study is in line with Houari et al. (2014), Almanaseer and Matarneh (2015) which state that intellectual capital affects leadership.

#### *C. The Influence of Intellectual Capital on Motivation*

Intellectual capital also has a profound effect on motivation, which means that an increase in intellectual capital can elevate the motivation. Intellectual capital consists of human capital, customer capital and technology capital which cannot be imitated and characterized as irreplaceable, three aspects that powerful to create a competitive advantage. Human capital will increase whenever the organization keens enough to apply its architect's knowledge into its architecture creation. While customer capital is a component of intellectual capital that provides tangible value. This element takes form in the harmonious relationship owned by architect with its partners, whether they come from reliable and qualified suppliers, loyal customers who are satisfied with the organization's services, or the organization's relationship with the surrounding community. As technological capital is the

ability of architects to fulfill routine organizational and technological processes that support architects' efforts to produce optimal intellectual work performance and overall business performance. From this explanation it is clear that Intellectual Capital has the potential to advance the organization, so as to increase work motivation. The result of this study conforms with Darmayanti et al, (2014), Sivalogathasan and Wu (2015) which state that intellectual capital affects motivation.

#### *D. The Influence of Intellectual Capital on Architect's Work Performance*

Intellectual capital affects the work performance of an architect which means that the higher the intellectual capital the better the work performance of the architect. The loading factor for intellectual capital that provides the greatest contribution in improving architect performance is customer capital. The architect's success is greatly influenced by their routine efforts to maximize the values of his intellectual capital. As Edvinsson (1997) argues that intellectual capital are composed from applied experience, organizational technology, customer relations, and expertise in the workfield which can create competitive advantages. Architects who have good intellectual capital are architects who have a competitive advantage.

By conducting intellectual capital management, it can be beneficial to provide information about architects' abilities, how to do their activities in a good way, providing information for recognizing architects progress in developing their knowledge also providing information about the development of the knowledge source as well. The result of this study is in line with Helmiatin (2015) and Sutanto also Siswanta (2014) who state that intellectual capital affects work performance.

#### *E. The Influence of Leadership on Architect's Work Performance*

Leadership also affects the work performance of architects, which means that the better the leadership applied, the better architect's work performance can be improved. Based on the factor loading indicator that able to give the biggest contribution in improving the work performance of an architect is giving solutions, reflected in the success achieved due to carrying out work procedures.

Leadership is an effort to influence many people through communication in order to achieve goals, or a means to influence people with instructions or commands, actions that cause others to respond and lead to better change, an important dynamic force that coordinates the organization in order to achieve goals, the ability to create self-confidence and support among subordinates so that goals can be achieved.

Essentially, inside leadership there are some elements such as the ability to direct, to influence, or to set the level of behavior of other people or groups toward goals. Leadership tends to set examples of behavior so that its subordinates can imitate it, convey high expectations about the work of subordinates and at the same time show high self-confidence in their subordinates, tend to behave that can bring up relevant motives that in accordance to the group mission. The result of

this study is in line with Marpaung (2014) and Muizu (2014) which state that leadership has an effect on work performance.

#### *F. The Influence of Motivation on Architect's Work Performance*

Motivation also affected on the work performance of an architect, which means that the higher the level of work motivation the better it can improve the work performance from the architect. Based on the factor loading indicator, motivation that able to give the biggest contribution in improving architect's work performance is fair treatment, as reflected in carrying out assignments according to their competence. Motivation is an important variable, where it needs to accept great attention from the architects in their progress to improve the work performance. Work motivation is an impulse that arises within architect's mind for doing or working on something because of any external stimulus comes from the employer and the work environment, as well as the basis for fulfilling needs and satisfaction feeling, also realization of responsibility for assigned tasks. If the behavior leads to a goal and equipped with ample motivation then the maximum achievement of targets is possible to obtain, so that the implementation of the work can be done as well with expected result of the best work performance from the architect be achieved.

In the heart of every architect lies an expectation of making a great achievement, and to achieve this success requires quality resources. To create a qualified architect, it takes a strong support towards its goal. This encouragement can be found in the form of providing motivation to architects with a view to improve their work performance. Architects who have high motivation will work optimally until their work outcomes also increase. The result of this study is in line with Sitorus and Soesatyo (2014) also Rahmayanti (2014) which state that motivation affects work performance.

#### *G. The Influence of Intellectual Capital on Architect's Work Performance Through Leadership*

Leadership mediates the influence of intellectual capital on architect's work performance, which means that intellectual capital can improve the architect work performance when leadership is applied in accordance to pre-determined operational standards. Intellectual capital plays an important role in the work performance of architects because this capital can find out the extent or how far the progress and capabilities owned by architects which can also be used as a consideration for developing organizations in the future. Intellectual capital also has important role in improving architect work performance, because it can be utilize by the organization to create the expected work performance, also as an evaluation instrument to gauge architects work performance in order to create a resilient architect who must survive in the future.

#### *H. The Influence of Intellectual Capital on Architect's Work performance Through Motivation*

Motivation mediates the influence of intellectual models on architect's work performance, which means that intellectual capital can improve work performance when the architects have high work motivation. Motivation is giving

inner encouragement to make other parties take certain actions and create series of encouragements aimed not only to others but also to themselves, thus, through this encouragement hopefully they can act towards the desired goal. An architect's motivation begins with a need, desire and urge to act in order to achieve those needs or goals. This explanation indicates the magnitude of the urge (drive), effort, intensity, and willingness to sacrifice in order to achieve goals. The stronger the motivation, the higher the work performance. Motivation for architects plays an important role in improving the work performance. Therefore, it is necessary to provide sufficient motivation to architects to elicit a better and optimum work performance from them.

## VI. CONCLUSIONS AND SUGGESTIONS

### A. Conclusion's

1. Intellectual capital is formed by human capital, structural capital and customer capital. The biggest contribution onto the formation of intellectual capital is human capital, which is described as working to the fullest. Leadership is formed from being fair, giving suggestions, supporting goals, catalysts, creators of security, representatives of work teams, sources of inspiration and respect. The biggest contribution to the formation of leadership is supporting goals, which is reflected in the respondent who can communicate smoothly with the work team. Motivation is formed from appropriate wages, job security, respect and recognition, fair treatment, interesting work atmosphere and attractive positions. The biggest contribution to the formation of motivation is an interesting working atmosphere, which is reflected in the respondent working according to the agreed plan. Architect performance is formed from the concept of design, pre-design, design development, drawing work, procurement of construction executives, and periodic supervision. The biggest contribution to the formation of Architect's performance is the design concept, which is reflected in the respondent's sketching of ideas.
2. Intellectual capital influences leadership, this statement shows that intellectual capital is a resource owned by an architect, which later can provide benefits in the future as seen from his leadership. The result of this study is in line with Houari et al. (2014), Almanaseer and Matarneh (2015) stated that intellectual capital affected on leadership.
3. Intellectual capital has the potential to improve architect's work performance so it able to increase the work motivation too. The result of this study is in line with Darmayanti et al, (2014), Sivalogathan and Wu (2015) stated that intellectual capital affected on motivation.
4. Intellectual capital is a formation of applied experience, organizational technology, customer relations, and expertise that can create competitive advantages, thereby will enhance the work performance of an architect. The result of this study is in line with Helmiatin (2015) and

Sutanto also Siswanta (2014) stated that intellectual capital affected on work performance.

5. Leadership is a way of influencing people with instructions or commands, or actions that cause others to respond and willing to be directed to better changes which impacted on architect's work performance. The result of this study is in line with Marpaung (2014) and Muizu (2014) stated that leadership has an effect on work performance.
6. Work motivation is an impetus that arises within an architect's mind to carry out activities ignites by external stimulus, both from the employer and the work environment, as well as the basis for fulfilling needs and feelings of satisfaction, and completion of responsibility for the tasks given and carried out within the organization that able to improve the architect's work performance. The result of this study is in line with Sitorus and Soesaty (2014) also Rahmayanti (2014) stated that motivation affected on work performance.
7. Leadership mediates the influence of intellectual capital on architect's work performance, which means that intellectual capital owned by the leader can improve architect's work performance when leadership is well implemented.
8. Motivation mediates the influence of intellectual capital on architect's work performance, which means that intellectual capital can improve the work performance when architects possess high work motivation during work completion.

#### B. Suggestion's

##### 1. Benefits for the science's development.

In establishing the concept of improving architect's work performance that related to leadership and motivation, it is necessary to develop and improve ways of utilizing human capital for improving the architect's work performance to achieve goals through an interesting working atmosphere when realizing or working on a design concept.

##### 2. Benefits for the Architects.

Architects as a human capital need to improve their work performance through trainings and the application of work operational standards. By training for architects in the framework of drafting design concepts, there is necessary to introduce the latest materials and up to date technology.

##### 3. Benefits for further researches.

The result of this study can be used as a reference in conducting further researches which related to the field of architect's work performance improvement which is influenced by intellectual capital through leadership and motivation aspects such as training and competency factors.

#### REFERENCES

- [1] Abraham H. Maslow, "Hierarchy of needs: a theory of human motivation," New York, Wilder Publications, 1943.
- [2] Almanaseer Mousa and Bashar Matarnah, "The impact of leadership patterns on the development of intellectual capital in the educational sector in The Kingdom of Bahrain," *Research Journal of Finance and Accounting*, vol. 6, no.2, 2015.
- [3] Darmayanti, Ni Putu, I Wayan Bagia, and I Wayan Suwendra, "Pengaruh kompetensi intelektual dan motivasi berprestasi terhadap kinerja pegawai pada Perusahaan Daerah Air Minum (PDAM) di Kabupaten Gianyar," *E-Journal Bisma, Ganesha Education University, Departement of Management*, vol. 2, 2014.
- [4] Deo Sansha Sitorus and Yoyok Soesaty, "Pengaruh kemampuan, motivasi kerja, dan komitmen organisasi terhadap kinerja karyawan," *Journal of Management*, vol. 2, no. 3, 2014.
- [5] George R. Terry, "Principles of management," 6th Edition, Illinois, Richard D. Irwin Homeword, 1972.
- [6] Harbani Pasolong, "Kepemimpinan birokrasi," Bandung, CV. Alfabeta, 2008.
- [7] Helmiatin, "Optimalisasi peran modal intelektual terhadap kinerja karyawan," *Journal Etikonomi*, vol. 14, no. 1, pp. 51-68, 2015.
- [8] H. Itami, "Mobilizing invisible assets," London, United Kingdom, Harvard University Press, 1987.
- [9] H. Maaradj, "The role of intellectual capital in the managerial leadership processes: a study based on the views of a sample of managers selected from a pipeline company in Ghardaia Province, Algeria," *Greener Journal of Business and Management Studies*, vol. 4, no. 1, pp. 001-013, 2014.
- [10] L. Edvinsson and M. Malone, "Intellectual capital: realising your company's true value by finding its hidden brainpower," New York, Harper Collins, 1997.
- [11] Marudut Marpaung, "Pengaruh kepemimpinan dan team work terhadap kinerja karyawan di Koperasi Sekjen Kemendikbud Senayan Jakarta," *Journal Scientific Widya*, vol. 2, no. 1, 2014.
- [12] Mamduh Hanafi, "Manajemen," 3th Edition, Yogyakarta, Universitas Gajah Mada, 2011.
- [13] Mohamad Mahsun, "Pengukuran kinerja sektor publik," Yogyakarta, BPFE, 2006.
- [14] Natalia Sutanto and I Gede Siswantaya, "Pengaruh modal intelektual terhadap kinerja perusahaan pada perusahaan perbankan yang terdaftar di Bursa Efek Indonesia," *Journal Modus*, vol. 26, no 1, pp. 1-17, ISSN 0852-1875, 2014.
- [15] Organization for Economis Co-Operation and Development (OECD), "International symposium for measuring and reporting intellectual capital: experience, issue, and prospects," Amsterdam, 1999.
- [16] Rahmayanti, "Pengaruh motivasi kerja terhadap kinerja karyawan pada CV. Putra Kaltim Samarinda," *E-Journal of Business Administration*, vol. 2, no. 2, pp. 215-229, 2014.
- [17] Republic of Indonesia Law, "Arsitek," no. 6, Jakarta, 2017
- [18] S. Firer and S.M. Williams, "Intellectual capital and traditional measures of corporate performance," *Journal of Intellectual Capital*, vol. 4, no. 3, pp. 348-360, 2003.
- [19] V. Sivalogathanan and Xiaobo Wu, "Impact of organization motivation on intellectual capital and innovation capability of the textile and apparel industry in Sri Lanka," *International Journal of Innovation Science*, vol. 7. No. 2, pp. 153-168, 2015.
- [20] Wa Ode Zusnita and Muizu, "Pengaruh kepemimpinan terhadap kinerja karyawan," *Journal of Business and Economy*, vol. 6, no. 1, pp. 1-13, 2014.
- [21] Yeremias T. Keban, "Enam dimensi strategis administrasi publik: konsep, teori, dan isu," Yogyakarta, Gaya Media, 2004.