

3_The_Influence_of_Intellectua l_Capital_and_Competyency.pdf

by Breeze Maringka Breeze Maringka

Submission date: 22-Dec-2023 02:06AM (UTC-0800)

Submission ID: 2264038350

File name: 3_The_Influence_of_Intellectual_Capital_and_Competyency.pdf (365.09K)

Word count: 7238

Character count: 42583

The Influence of Intellectual Capital and Competency to Architects' Workperformance Through Training in Malang City

Breeze Maringka, Nusa Sebayang
National Institute of Technology Malang

Abstract— This study aims to describe intellectual capital, competence, training and workperformance of architects, to analyze the influence of intellectual capital and competence on training, to analyze the effect of intellectual capital and competency on the architects' workperformance, to analyze the effect of training and competency for the architects' workperformance, and to analyze the effect of intellectual capital and competency to architects' workperformance through training. Total sample of this study was 186 architects and the analysis technique applied for this study was a structural equation modelling/SEM with result analysis showed the intellectual capital and competency affect the architects' workperformance. Training also affects on the architects' workperformance because it is able to mediate the influence of intellectual capital and competency to architects' workperformance.

Keywords— Intellectual modal, competence, training and architects' workperformance.

I. INTRODUCTION

The architect's workperformance is an architect's service as described in Republic of Indonesia Law Number 6 of 2017 about architect. In this study, the workperformance of architects was the object to be examined because architects become the originator/creator of any planning/development ideas. The research was conducted in *Malang Raya* (Greater Malang) with consideration of vast planning and constructions of buildings are progressing in these areas. The planning and construction of these buildings at some extents related to the workperformance of architects, particularly with the architects in Malang city. With such rapid planning and development as well as the IAI ongoing activities in the form of exhibitions, competitions, seminars and workshops, this is the perfect time to conduct a research about the workperformance of architects which never been conducted prior to this day.

The development of a new economy controlled by technology and knowledge brings highlight to Intellectual Capital (Hong, 2007). According to Kamukama and Ntayi (2011) the intellectual capital consists of two components: human capital and structural capital whereas the result of researches from Kamukama & Ntayi (2011), Sutanto & Siswantaya (2014), Helmiatin (2015) and Maringka & Sebayang (2020) proven that intellectual capital affected the workperformance of architects. Thus, intellectual capital is a form of competitive advantage which in the high level of competition in the industry like nowadays, architects need

competitive advantages to be able to strive and compete against other architects.

Aside from intellectual capital, one factor that affects the architects' workperformance is a training, and in every big or small organizations, all of them needs qualified human resources. Human resources are one of the key factors for a success of an organization. Therefore, a competent and adaptable personnel management is needed to overcome the existing challenges in human resources field. One way to solve this problem is by providing a training program which aims to improve and to upgrade the architects' quality so they will able to solve the existing problems and also able to improve the architects' workperformance in competitive rivalry in the present time. A training is an activity that made by organization which intends to improve and to develop attitude, behaviour, skill and knowledge of the architects in accordance to the organization expectations. There are many factors affect the architects' workperformance which one of them is competence (Mathis and Jackson, 2001:82). A competency refers to rational actions to meet certain specifications in carrying out tasks within the organization and as it is said to be rational actions because these acts have clear directions and purposes/goals. The employees placement in job positions as accordance to their competencies is one determining factor in improving the workperformance. The result of researches of Elizar & Tanjung (2018) and Syahputra & Tanjung (2020) found that competency affected on workperformance, meanwhile, the result of researchers of Marga (2016), Widijanto (2017), Rusli (2018) and Halawi & Haydar (2018) also proved that training has an effect on workperformance. The novelty of this research is put a training as an intervening variable which affects the intellectual capital to the architects' workperformance.

The result of this study will contribute to fields of Human Resource Management; Intellectual Capital, Competence/Competency, Training, and Workperformance of Architects, also to contribute insight for architects about the intellectual capital which able to improve their workperformance through training.

II. LITERATURE REVIEW

Workperformance

Ilyas (1999:99) gave definition about workperformance as the appearance of the work of personnel both in the quality and quantity aspects within an organization. It can be the appearance of work individual or work in group personnel. The

appearance of the work will not be limited to personnel who hold the functional and structural positions, but also to the entire line of personnel within the organization.

In relation to this, the Architect Performance Standard in a work relationship between architects and their service users are interpreted as the same as an architect's work stated as follows: the architects' work performance is a document consisted of results of architectural designs which includes; Drawings, Workplan and its requirements (*Rencana Kerja dan Syarat-Syarat/RKS*), Budget Plan (*Rencana Anggaran Biaya/RAB*), Bill of quantity, and other reports. The result of works related to architects' main services is explained in work stages as follow; the design concept stage, the schematic design stage, the design development stage, the working drawing stage, the construction procurement process stage, and the periodical inspection stage.

Intellectual Capital

Intellectual capital according to Edvinsson (1997) is the applied experiences, organizational technology, customer relations, and expertise which able to create a company's competitive advantage. In line with this definition, The Organization for Economic Co-Operation and Development (OECD, 1999) describes intellectual capital as the economic value of two categories of company intangible assets: Organizational (structural) capital and Human capital. The structural capital are proprietary software and systems, distribution networks, and supply chains, meanwhile the Human capital includes human resources within the organization and from outside the organization such as customers and suppliers.

Many practitioners define the intellectual capital has three main elements of human capital, customer capital and structural capital (Kamukama & Ntayi, 2011; Shih & Lin; 2010). The intellectual capital often described as knowledge resources in the form of employees, customers, processes or technology that company can use in the process for creating its value, which conformed by Mehrilian et.al (2013) statement of three elements; knowledge related to employees (referred as *Human Capital*), knowledge related to customers (referred as *Relational Capital*), and knowledge related to the company (referred as *Structural/Organization Capital*) that will build the intellectual capital for the related company.

Competency

Competency according to Wibowo (2016) is the ability to carry out or perform a work and task based on skills and knowledge, supported by the work attitude required by the work. Marwansyah (2016) argues, competency is a combination of knowledge, skills, attitudes and other personal characteristics needed to achieve success in a work that able to be measured by certain agreeable standards and can be improved through given trainings and development activities. Align with these statements, Spencer and Spencer (2007) define competence as a characteristic underlies an individual related to the effectiveness of an individual's performance in his work. Further, Mitrani in Busro (2018) added, competence is a deep and inherent part of an individual and a predictable behavior in various situations and work tasks.

The competency indicators according to Spencer and Spencer (2007:9) consist of: motive, target, trainer, material, method and training participant. A motive is inner thought which consistently think or want from an individual that resulted an action. The motive drives, directs, and selects appropriate behaviour toward certain actions or goals. Behaviour is the physical characteristic and consistent responses to situations or information, such as a fast reaction (speed of reaction) and accuracy sightness (the sharpness of the eyes) which become the physical characteristics of a fighter pilot's competency. A self concept is the attitudes, values or self-image of an individual, whereas the self-confidence is people belief that everyone can be effective to almost any situation as the part of individual's self-concept. Then, knowledge is a complex of competencies, whereas skill is the ability to do certain physical or mental tasks, and mental competency or cognitive skills are created from an analytical and conceptual thinking.

Training

Training according to Dessler (2015) is a process of teaching new or existing employees the basic skills needed in carrying out their work. Training becomes one effort to improve human resource quality in workfield. The employees, both new and already working employees need to participate in trainings due to flexible changes of job demands when changes occurred in the work environment, in the work strategies, and so on.

The training indicators according to Triton (2010:87) are: (a) *Objective*; a training is composed by set of goals which in particular related to preparation of action plans (*action play*) and target setting, also the expected result of the training which about to be held, (b) *Target*; training objectives must be determined with detailed and measurable criterias, (c) *Trainers*; since training in general has orientation toward skill improvements, the selected trainers must able to provide competent training materials and must have adequate qualifications related to their field as a professional and competent trainer, (d) *Materials*; a human resource training requires appropriate material or curriculum that in accordance with the achieved objectives of the human resource training for the related organization, (e) *Methods*; training methods will ensure the effective process of human resource training activities when these aspects are in accordance with type of materials and abilities of the trainees, (f) *Training participants*; participants must be selected based on certain requirements and appropriate qualifications.

Research Hypothesis

The formulation of proposed hypothesis in this study are stated as follow:

H₁: The Intellectual Capital and Competency are suspected to have a significant effect on Training.

H₂: The Intellectual Capital and Competency are suspected to have a significant effect on Workperformance

H₃: Training is suspected to have a significant effect on the Workperformance of architects.

H₄: The Intellectual Capital and Competency are suspected to have a significant effect on the

Workperformance of architects through Training.

III. RESEARCH METHOD

The Operational Definition of Variables

The operational definition of a variable presents the researcher's approach in measuring a variable. Exogenous variables and endogenous variables measurements were conducted by applying an interval scale, while the measurement of independent and dependent variables were conducted by giving scores ranging from 1 to 5 points or known as The 5 points Likert Scale. Here, the operational definition from each variable will be explained as follow:

a. Architects' Workperformance

Workperformance is the resulted work of architects in the form of an architectural design document. The indicators for workperformance are: Concept Design ($Y_{2.1}$), Design ($Y_{2.2}$), Design Development ($Y_{2.3}$), Making Working Drawings ($Y_{2.4}$), Procurement of Construction Executors ($Y_{2.5}$) and Periodic Supervision ($Y_{2.6}$).

b. Intellectual Capital

Intellectual Capital is a knowledge resource in the form of employees, customers, processes or technology which the company can use during the process of creating value for the company. The indicators for intellectual capital are: Human Capital ($X_{1.1}$), Customer Capital ($X_{1.2}$), and Structural Capital ($X_{1.3}$).

c. Competency

Competency is the ability of the Architect in carrying out the work. The indicators for competency are: motives, traits, self-concept, knowledge and skills.

d. Training

Training is a way to create, add, develop, or improve work skills of architects and the indicators for training in this study are: Objective ($Y_{1.1}$), Target ($Y_{1.2}$), Trainer ($Y_{1.3}$), Material ($Y_{1.4}$), Method ($Y_{1.5}$), Training Participants ($Y_{1.6}$),

Population, Sample and Location of The Study

The population of this study is architects in Malang area who are members of architect professional association *Ikatan Arsitek Indonesia* (Indonesian Architects Association) Malang region amounted of 657 architects (six hundred and fifty seven people) (IAI Malang, 2018).

The sample of this study were active architects in Malang region based on the report of Head of *Ikatan Arsitek Indonesia* from Malang region with total sample of 186 (one hundred and eighty-six) architects who were selected by census. These sample number has met the requirements for applying the Structural Equation Model (SEM) as the analytical tool for this study, where the required samples are ranging from 100 (one hundred) to 200 (two hundred) people.

Malang Raya (Greater Malang) was selected as research location due to certain considerations:

- Planning and construction of many buildings in *Malang Raya* (Greater Malang) are developing rapidly nowadays. It can be seen clearly from variety constructions of houses/residential buildings, shopping centres, government/private office buildings, hospital, hotel buildings and others.

- Malang city is known as a city of education and tourism also famous as a city of industry which recently has shifting more to become a tourist and culinary city similar to Batu city that also growing so rapid as a tourist city, as well as Malang regency that also grows and flourish with many tourism destinations. These pillar cities resemble one unique value of *Malang Raya* (The Greater Malang) to become its distinctive attraction to visit.
- Malang Raya* (The Greater Malang) has architect association named *Ikatan Arsitek Indonesia of Malang Raya* region which continuously growing and developing activities to support architect profession such as ongoing seminars, workshops, professional upgrading, architectural services to the community, technical guidance to the Malang city government (for its Tourism Village), become members of the Malang city TABG (Building Expert Team), training tests for architects, and participate in national and international exhibitions of architects' works.

The Analysis Data Technique

The analytical techniques applied in this study were a descriptive analysis and structural equation modelling (SEM). The descriptive analysis technique was chosen for determining the characteristics of respondents as measured from numbers of indicators which stated in the questionnaire. The descriptive analysis technique will generate the frequency value and mean value of each indicator, where the displayed frequency values include amount and percentage will be presented in tabulation/tabular form. The software selected for the descriptive analysis was IBM Statistic SPSS 21 then, through SEM, the effect of exogenous variables to endogenous variables can be described and analyzed.

IV. RESULT AND DISCUSSION

SEM Assumption Test Result

From data processing result of this study, the multivariate CR value was 1.327 which between -2.58 to 2.58, so it can be concluded that multivariate normality assumption has been fulfilled, thus the normality assumption required by SEM analysis has been fulfilled.

Meanwhile, from the result of *Mahalanobis distance squared* (statistically) the χ^2 was observed outlier detected from observed point that has *Mahalanobis distance greater than the Chi Square table* ($df = 20, \alpha = 0,001$) by value of 45.315, however, from the result analysis of this study, there are no outlier found in 20 indicators applied in this study.

The Goodness of Fit Testing

According to the literature review and the aims of this study, then a complete structural model is developed as displayed below:

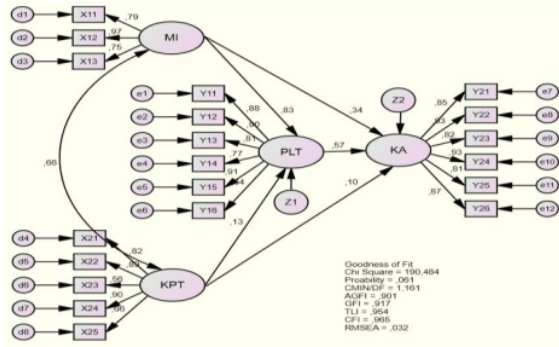

Source: Primary Data Tabulation, 2021. Picture 1

The Result of SEM Analysis

From the AMOS 18 computation for the SEM model, the goodness of fit indices were generated and presented in table 1. Then, these index values were compared to the critical value (cut-of value) of each index. A good model is expected to have goodness of fit indices that are greater than or equal to the critical value. Goodness Of Fit Test Results Modified Structural Model

TABLE 1. Result of The Goodness of Fit Test Results Modified Structural Model

Goodness of Fit Index	Cut-off Value	Result Model	Category
Chi-Square	194,113	190,484	Good
Probability Chi-Square	>0,05	0,061	Good
CMIN/DF	≤2,00	1,161	Good
RMSEA	≤0,08	0,032	Good
GFI	≥0,90	0,901	Good
AGFI	≥0,90	0,917	Good
TLI	≥0,95	0,954	Good
CFI	≥0,95	0,965	Good

Source: Primary Data Tabulation, 2021.

Based on results of evaluation the Goodness of Fit Indices criterias as presented in table 1, it showed the overall model evaluation has met criteria, the model can be accepted.

Testing of Hypothesis One

Hypothesis one states the intellectual capital and competency have significant effect on training based on the result analysis of hypothesis one testing as presented in table 2.

TABLE 2. The Influence of Intellectual Capital and Competency to Training

Variable	Standardized Regression Weight	Estimation	S.E	C.R.	P
Intellectual Capital	0,828	0,940	0,087	10,765	0,000
Competency	0,133	0,151	0,064	2,352	0,019

Source: Primary Data Tabulation, 2021.

Table 2 shows the intellectual capital and competency variables have a critical ratio (CR) value higher than 2 and the p-value is less than or equal to 0.05. In the form of standardized regression weight coefficient, the intellectual capital value is 0.828 while the competence value is 0.133. These results give

decision that the intellectual capital variable has a positive and significant effect on training variable. Therefore, the proposed hypothesis one which states intellectual capital and competency have a significant effect on training is statistically tested.

Testing of Hypothesis Two

Hypothesis two states intellectual capital and competency have a significant effect on workperformance based on the result analysis of hypothesis two testing as presented in table 3.

TABLE 3. The Influence of Intellectual Capital and Competency to Architects' Workperformance

Variable	Standardized Regression Weight	Estimation	S.E	C.R.	P
Intellectual Capital	0,338	0,346	0,103	3,355	0,000
Competency	0,100	0,102	0,045	2,277	0,023

Source : Primary Data Tabulation, 2021.

Table 3 shows the intellectual capital and competency variables have a CR value higher than 2 and the p-value less than or equal to 0.05. In the form of standardized regression weight coefficient, the intellectual capital value is 0.338 while the competency value is 0.100. These results give decision that the intellectual capital and competency variables have a positive and significant effect on the architects' workperformance. Therefore, the proposed hypothesis two which states the intellectual capital and competency have a significant effect on the architects' workperformance is statistically tested.

Testing of Hypothesis Three

The third hypothesis states training has a significant effect on the architects' workperformance based on the results analysis of hypothesis three as presented in table 4.

TABLE 4. The Influence of Training to Architects' Workperformance

Variable	Standardized Regression Weight	Estimation	S.E	C.R.	P
Training	0,567	0,510	0,096	5,317	0,000

Source: Primary Data Tabulation, 2021.

Table 4 shows the training variable has a CR value higher than 2 and the a p-value of 0.000 which less than or equal to 0.05. In the form of standardized regression weight coefficient, the training value is 0.567. This result gives decision that the training variable has a positive and significant effect on the architects' workperformance. Therefore, the proposed hypothesis three which states the training variable has a significant effect on the architects' workperformance is statistically tested.

Testing of Hypothesis Four

The fourth hypothesis states intellectual capital and competency have a significant effect on the performance of architects through training based on the results analysis of hypothesis fourth as presented in table 5.

TABLE 5. The Influence of Intellectual Capital to Architects' Workperformance Through Training

Variable	Direct Influence	Indirect Influence	Total Influence
The Intellectual Capital to Architects' Workperformance through Training	0,338	0,828 X 0,567 = 0,469	0,807
Competency toward Architects' Workperformance through Training	0,100	0,133 X 0,567 = 0,075	0,175

Source: Primary Data Tabulation, 2021.

Table 5 shows training is a variable that able to mediate the intellectual capital variable to architects' workperformance because the total influence value is higher than the direct effect (0.807> 0.338). Training has status as a variable that able to mediate the competency variable to the architects' workperformance, because the total influence value is greater than the direct effect (0.175> 0.100). The data interpretation means the intellectual capital and competency variables have a significant effect on the architects' workperformance through training has been statistically tested.

Discussion

The Description of Intellectual Capital, Competency, Training and Architects' Workperformance

The architects' workperformance composed from the concept of design, pre-design, design development, procurement of working drawings, procurement of construction implementers and periodic supervision. The biggest contribution to the formation of architects' workperformance is the procurement of construction implementers reflected in preparation of tender documents. An architect must be skilled or be able to plan and design buildings and also able to coordinate construction. The minimum role of architects are take responsibility for design, documentation, and licensing. However, architects play imminent role in all aspects from a project; from involvement in site selection to feasibility studies through construction supervision and project completion procedures. The architects' workperformance is the architects' work as a result of architects practices which carried out by architects (as stated in The Guildelines for Working Relationship Between Architects and Service Users, 2007).

The intellectual capital is composed from human capital, customer capital and technology capital. The biggest contribution to the formation of intellectual capital is human capital as reflected from respondents that work in their full abilities. The human capital focuses on architects' value which exist in a company and the knowledge that they have. Human capital is a medium where the whole level of achievement begins; the source of innovation and the beginning of knowledge, and the viewpoint in intellectual capital must relate to the organization, not with the individual. As Edvinsson (1997) stated the intellectual capital is applied experiences, organization technology, customer relations, and expertise which can create a company's competitive advantage. Therefore, the intellectual capital plays a role in the success of architects.

The competency is formed from motives, traits, self-concept, knowledge and skills. The biggest contribution to the formation of competence is reflected in the nature of working with humanists. Competency is an ability to carry out a job or task based on skills and knowledge and is supported by the work attitude required by the job. Thus, competency shows skills and knowledge that are characterized by professionalism in a particular field as the most important or superior thing in that field. As Mitrani argues in Busro (2018:25) competency is a deep and inherent part of a person and predictable behavior in various situations and job tasks.

The training is formed from goals, objectives, trainers, materials, methods, and training participants. The biggest contribution to the formation of training is the trainer as reflected in the trainer's ability. By conducting training, architects gain knowledge, abilities, and skills in accordance with the work that architects do. Training is considered as one of the effective media to improve the ability of architects and support the pace of organizational development. As Simanjuntak (2011) stated training is part of human investment in improving work abilities and skills, and thereby improve employees' performance. Training is usually carried out with a curriculum that is tailored to the needs of the position, given in a relatively short time, to equip an individual with job skills.

The Influence of Intellectual Capital and Competency on Training

The intellectual capital has an influence on training where higher intellectual capital will able to improve training. Type of intellectual capital which able to make the biggest contribution in training upgrading/improvement is customer capital. Customer capital is collection of knowledge of series of markets, customers, suppliers, good relations between the government and industry or with outside parties. The customer capital is the component of intellectual capital which able to provide real value. This indicator is taking a form of harmonious relationship between the organization and its partners; whether it comes from the reliable and quality suppliers, from loyal customers who are satisfied with the organization's services, also from the organization's relationship with the government and its surrounding community. The organization must able to create a distinctive goods and services and earn more values in the consumer' eyes. Customer capital also includes ability to identify the targeted market and positioning the organization in the market. It can be created through the employees knowledge which processed by structural capital and gain ultimate result of good relationships with outside parties. These purposes can be achieved through making investment in architect's trainings, advances in technology and information updates as well as making organizational procedures. In addition, to upgrade the awareness and technical ability in assessing type of intellectual capital related to financial reports, the company/organization can send their architects to attend seminars or trainings about intellectual capital realm. As Edvinsson (1997) stated the intellectual capital is applied experience, organizational technology, customer relations, and expertise which able to create the company's competitive advantage. Thereby, the

intellectual capital plays a major role in the success of the architects.

The competency also has an influence on training where higher competence owns by architects will require higher level of trainings. The competency indicator which brings biggest contribution in improving trainings is reflected in having certain technical skills. The architects' high skills for conducting their duties and activities are obtained along their period of work in their discipline field. To complete a job or given task, an architect needs skills which support the individual for completing the related work. An architect competency will be recognized when the individual is able to handle all design problems starting from design concept preparation to periodic supervision where eventually becomes a finished architectural product. In principle, a competency will be able to shape personalities and increases knowledge of an architect when performing work task to be quicker and more precisely. Thus, the higher competence level of an architect, the higher the level of trainings which will be attended by the architect in pursuit of developing architects' knowledge and skills. As Marwansyah (2016) argues, competency is a combination of knowledge, skills, attitudes, and other personal characteristics needed to achieve success in a job, which can be measured by agreeable standards and can be improved through certain trainings and development. Therefore, competency plays an important role in organizations due to its part for simplify the organization in search of finding the right type of work after knowing the employees' competencies, then the organization can help to develop employees' skill through training.

The Influence of Intellectual Capital and Competency on Architects' Workperformance

The intellectual capital has an influence on architects' workperformance where the higher intellectual capital will able to improve the architects' workperformance. Intellectual capital is the ability needed to carry out various mental activities of thinking, reasoning and solving problems of an architect. It is a resource owned by a company which will provide benefits in the future. The intellectual capital dimensions consists of knowledge related to human capital, costumers, and company's related knowledge that will construct one intellectual capital for the company. Intellectual capital is crucial for the company because it can determine the extent of certain progress and capabilities owned by architects, which also able to be used as a consideration for company development in the future. Organization capabilities in the field of science and technology is one of many vital competitive factors. Human resources and knowledge have created added value and competitive advantage for organization. It shows a competent intellectual capital management will able to improve the workperformance of an architect. The result of this study supports Kamukama & Ntayi (2011), Sutanto & Siswantaya (2014), Helmiatin (2015) and Maringka & Sebayang (2020) which stated that intellectual capital affects workperformance.

The competency also has an influence on architects' workperformance, where the higher competency of an architect makesahigher workperformance of an architect, too. On the contrary, lower competence of an architect will bring less

workperformance of an architect, too. This comparison brings fact an architect will be competent when he or she always eager to look up information during completing the work task with a support existed from the organization in the form of facilities that able to provide science which able to support knowledge related to architect's discipline for completing the work. Spencer and Spencer (2007) stated a competency is a characteristics that underlies an individual and related to the effectiveness of this individual performance in his work. Competence is a fundamental characteristic of an individual where includes causes associated to effective workperformance criterias. By this finding, it shows a competent architect will able to acquire and develop the task they carried out so the architects' workperformance level will have a good improvement. Competency plays essential role in supporting work routines. If an architect wants to get work satisfaction, then, an architect needs a competency related to his/her workfield, because basically competency consists of motives, traits, sel-concept, knowledge and skills. Therefore, it is necessary to give better attention and build competencies so the workperformance in terms of quality and quantity can be maintained. Ways to influence the excellent competencies flourish from architects is to create new creations which provide challenges for architects. Whereas for the architects, any work challenges will encourage architects to work seriously for getting the maximum result. Competency indicator which has significant contribution to workperformance improvement is skills reflected from having technical skills of the related field. Competency is an ability to perform a job or a task based on the skill and knowledge level and is supported by 'not difficult work attitude' for type of work that becomes his/her job. In summary, competency shows skills and knowledge characterized by a professionalism attitude in certain field as the most important part because in general, competency only concerns with the basic ability of an individual to do a task or a work. These result is conforming the study of Elizar & Tanjung (2018) and Syahputra & Tanjung (2020) which stated competency has a significant effect on workperformance.

The Influence of Training on Architects' Workperformance

Training has a significant influence on architects' workperformance where the better the architect's training application then the higher the workperformance of the individual. On the contrary, the lower architect's training application will bring less workperformance of the individual. Training is a popular method to raise architects' abilities that will be followed by reciprocal actions to improve abilities, which then, these built abilities are put in the right place where the existence of many supportive opportunities occur, therefore, abilities are very affecting the architects' workperformance. Architects become one important factor that must be considered by the organization in its effort to achieve the organizational goals. The organization development also influenced by technological developments. It is required the ability from the organization to manage all existing resources in a planned manner, especially in human resources area as the organization's operational personnel are the division who in charge to produce usefulness for every organization activities. The organization is expected to provide and create high skilled

and competent architects to perform many works that demanding a high work skill. After finishing selection and placement process, architects must be given an initial training so they can master the architects' field of work which in the end of the training will be useful for improving the ability and workperformance of the architects. The result of this study supports Marga (2016) and Widijanto (2017), Rusli (2018) and Halawi& Haidar (2018) statements that training has an effect on workperformance.

A training for architects is very important to be applied in an organization. By training, an architect is expected able to work in more effective and efficient way particularly when dealing with emerging changes such as technological changes, work methods changes, demand changes, attitude changes, or behavior, skill and knowledge changes. Thus, for organization who want to develop better, trainings for its architects must have a considerable attention, and when the organization decided to conduct trainings for its architects, explaining about the training objectives will be the first thing to do, so that direction or goals to be achieved are clearly defined. In general, training is conducted for the benefit of architects, organizations and society and it can be said that training purpose is to develop the knowledge, attitudes, work skills and morals of architects as an effort to elevate their workpower or architects' workperformanceso they are able to produce quality products as well as to close the gap between architect's work ability to the work demand, so a mutual beneficial condition will be achieved both for the organization and for the architects.

The Influence of Intellectual Capital and Competency on Architects' Workperformance through Training

Training mediates the influence of intellectual capital on architects' workperformance; the higher the intellectual capital the better its ability to improve the architects' workperformance, when supported by an application of the related training in accordance to the architects' necessity. An architect plays role as one of the key factor contributes to the success of an organization. So, competent and adaptable personnel management is needed to overcome challenges faced by architects, where providing training programs is one way to solve it. Training is intended to improve and raising the quality of architects so they able to tackle any existing problems and elevate their workperformance. A job training is an activity held by the organization which intended to improve and develop attitude, behavior, skill and knowledge of architects, in accordance to the expectation of the organization. These explanations are conforming the opinion of Simanjuntak (2011) which states training is part of human investment to improve work abilities and skills, and thereby improve the employees workperformance. Training is usually given in relatively limited/short time with curriculums tailored to the needs of the related job position, with aims to equip an individual with required job skills. The intellectual capital belongs to architects in general is sufficient to support the work completion, especially when this capital is supported by attending trainings that suitable for the architects' necessity for improving the architects' workperformance. Intellectual capital is related to human knowledge, their experiences and the technology they used. Intellectual capital has potential to advance the related

organization and the society. Intellectual capital includes all aspects of architects' knowledge, organization, and architects' ability to create added values leading to a sustainable competitive advantage. In general, the intellectual capital belongs to an architect already able to support the work completion, so as to improve the architects' workperformance. The intellectual capital plays a significant role for the organization because it can assess the extent of progress and abilities from the architects which also can be applied as consideration for organization in its future development plan.

Competency affects workperformance through training which means architects' workperformance can be improved if the architects has a good competency, and by knowing their own competences they can select type of trainings that must be attended to improve their workperformance. The architects' workperformance will improve when they can apply the result of trainings that they have been attended. This argument is align with Simanjuntak (2011) statements about training is a part of human investment for improving work abilities and skills, and thereby able to improve the workperformance. A high competence architect is an individual who have ability to understand how to work properly and correctly, understand the product quality standard sets by the organization also having abilities related to quick act (dexterity) and architectural skills in their work field. In line with these explanations, result of Elizar & Tanjung research (2018) proved training and competence have a significant effect on the workperformance. With positive work skills, the organization has created attitude for architects for performing their job as effective as possible. The result of this study supports research of Syahputra & Tanjung (2002) which state the competence affects workperformance.

V. CONCLUSIONS AND SUGGESTIONS

Conclusions

From the discussion in this study, the researchers draw some conclusions as follow:

1. The architects' workperformance is composed from the concept of design, pre-design, design development, procurement of working drawings, procurement of construction implementers also a periodic supervision. The biggest contribution to the formation of architects' workperformance lies on the procurement of construction implementers as reflected in the preparation of tender documents. The intellectual capital is formed from human capital, customer capital, and technology capital where the biggest contribution to the formation of intellectual capital lies on human capital as reflected from the respondents who work with full abilities. The competency is formed from motives, trait, self-concept, knowledge and skills and the biggest contribution to the formation of competence reflected in nature of working with humanists. Whereas training is formed from objectives, targets, trainers, materials, methods and training participants and the biggest contribution to the formation of training lies on the trainers as reflected in the trainer's ability.
2. The intellectual capital and competency have an effect on training, where the higher of the intellectual capital and the

competency of an architect will able to improve the trainings. By utilizing the intellectual capital and competencies belong to architects then it can improve the level of trainings.

3. Intellectual capital and competency affect the architects' workperformance; the higher the intellectual capital and competencies of architects, the higher the improvement in the architects' workperformance. A competent architect and intellectual capital are two resources owned by an organization which later will provide benefit in the future time.
4. Training affects the architects' workperformance; the better the training application the better the improvement of architects' workperformance. Trainings attended by architects play essential role in supporting the smoothness architects activities.
5. Training is able to mediate the influence of intellectual capital and competency to architects' workperformance; the higher the intellectual capital and competency of an architect the better the improvement architects' workperformance when supported by active participation of the architect to trainings for improving his/her abilities and skills.

Suggestions

According to the result and conclusion of this study, the intellectual capital and competency are able to improve the architects' workperformance through training, therefore, the suggestions for this study are as follow:

1. Theoretical Suggestion
The researchers suggest to enrich the concept of human resource management for improving the workperformance through training.
2. Practical Suggestions
 - a. The researchers suggest to better maintain performance of periodic supervision and to urge architects for be able to prepare the estimation of construction budget.
 - b. The researchers suggest for architects to master ICT to make their workload becomes light, cost effective and always innovatives.
 - c. The architects' workperformance can be improved through training, thus, it is expected the leader of organization will provide equal opportunities for architects to join trainings to make them more skillfull at work.

REFERENCES

- [1]. Dessler, Gary. 2015. *Manajemen Sumber Daya Manusia*. Jakarta: Salemba. Empat.
- [2]. Edvinsson, L. and Malone, M. 1997. *Intellectual capital: Realising your company's true value by finding its hidden brainpower*. New York: Harper Collins.
- [3]. Elizar, Elizar, dan Hasrudy Tanjung. 2018. Pengaruh Pelatihan, Kompetensi, Lingkungan Kerja terhadap Kinerja Pegawai. *Maneggio: Jurnal Ilmiah Magister Manajemen*. Volume 1 No 1: 46-58.
- [4]. Halawi, Ali dan Nada Haydar. 2018. Effects of Training on Employee Performance: A Case Study of Bonjus and Khatib & Alami Companies. *International Humanities Studies*. Vol. 5 (2): 24-45.
- [5]. Helmiatin, 2015. *Optimalisasi Peran Modal Intelektual Terhadap Kinerja Karyawan*. *Eikonomi* Volume 14 (1): 51 – 68.
- [6]. Hong, Pew Tan, David Pteyman and Phil Hancock. 2007. Intellectual capital and financial returns of companies. *Journal of Intellectual Capital*, Vol. 8 Issue: 1, pp.76-95, <https://doi.org/10.1108/14691930710715079>.
- [7]. Kamukama, N., Ahiauzu, A. dan Ntayi, J.M. 2011. Competitive advantage: mediator of intellectual capital and performance. *Journal of Intellectual Capital*. Vol. 12 No. 1: 152-164. .
- [8]. Marga, Yossy Kanta. 2016. Pengaruh pelatihan, kecerdasan emosional, dan budaya organisasi terhadap kinerja karyawan pada PT Pelayaran Tempuran Emas Surabaya. *E-Jurnal Manajemen Kinerja*. Volume 2 No. 1: 22-36.
- [9]. Maringka, Breeze A. S. dan Nusa Sebayang. 2020. Pengaruh Modal Intelektual Terhadap Kinerja Arsitek Melalui Kompetensi di Malang. *Pawon*.
- [10]. Marwansyah. 2016. *Manajemen Sumber Daya Manusia*. Bandung: Alfabeta.
- [11]. Mehralian, Gholamhossein, Hamid Reza Rasekh, Peyman Akhavan dan Ali Rajabzadeh Ghatari. 2013. Prioritization of intellectual capital indicators in knowledge-based industries: Evidence from pharmaceutical industry. *International Journal of Information Management*. 33. 1: 209-216.
- [12]. Organization for Economic Co-Operation and Development (OECD). 1999. *International Symposium for Measuring and Reporting Intellectual Capital: Experience, Issue and Prospects*. Amsterdam.
- [13]. Peraturan Menteri Pekerjaan Umum dan Perumahan Rakyat Republik Indonesia Nomor 11/PRT/M/2018. *Tentang Tim Ahli Bangunan Gedung, Pengkaji Teknis dan Penilik Bangunan*.
- [14]. Rusli, Gunar. 2018. Pengaruh Pelatihan dan Modal Intelektual Terhadap Kinerja Keuangan Perusahaan Perbankan yang Terdaftar di Bursa Efek Indonesia Tahun 2012 – 2015. *Jurnal Muara Muara Ilmu Ekonomi dan Bisnis*. Vol. 2, No. 1, April 2018: hlm 245 – 253
- [15]. Shih, K., Chang, C. dan Lin, B. 2010. Assessing knowledge creation and intellectual capital in banking industry. *Journal of Intellectual Capital*. Vol. 11 No. 1: 74-89.
- [16]. Simanjuntak, Payaman J. 2011. *Manajemen Evaluasi Kinerja*. Edisi 3. Jakarta. Fakultas UI
- [17]. Spencer, M.Lyle and Spencer, M. Signe, 2007. *Competence at Work: Models for Superior*. John Wiley & Son, Canada.
- [18]. Sutanto, Natalia dan I Gede Siswantaya. 2014. Pengaruh Modal Intelektual terhadap kinerja perusahaan pada perusahaan perbankan yang terdaftar di Bursa Efek Indonesia. *Modus Journals*. Vol. 26. No. 1: 1-17.
- [19]. Syahputra, Muhammad Dedi, dan Hasrudy Tanjung. 2020. Pengaruh Kompetensi, Pelatihan dan Pengembangan Karir Terhadap Kinerja Karyawan. *Maneggio: Jurnal Ilmiah Magister Manajemen*. Vol 3. No. 2: 283-295.
- [20]. Triton PB, 2010. *Manajemen Sumber Daya Manusia : Perspektif Partnership dan Kolektivitas*. Cetakan Pertama. ORYZA, Yogyakarta
- [21]. Undang-undang No. 6 Tahun 2017 tentang *Arsitek*. Jakarta.
- [22]. Undang-undang No. 6 Tahun 2017 tentang *Arsitek*. Jakarta.
- [23]. Wibowo, 2016. *Manajemen Kinerja*, Edisi Kelima, PT Rajagrafindo Persada. Jakarta.
- [24]. Widijanto, Kelvin Aldrian. 2017. Pengaruh Pelatihan Kerja dan Motivasi terhadap Kinerja Karyawan Divisi Karyawan di PT Sumber Hasil Sejati Surabaya. *Agora*. Vol. 5 No. 1.

3__The_Influence_of_Intellectual_Capital_and_Competency...

ORIGINALITY REPORT

4%

SIMILARITY INDEX

%

INTERNET SOURCES

3%

PUBLICATIONS

6%

STUDENT PAPERS

PRIMARY SOURCES

1

Submitted to Georgia College & State University

Student Paper

3%

2

Submitted to Universitas Merdeka Malang

Student Paper

2%

Exclude quotes Off

Exclude matches < 2%

Exclude bibliography Off