

Effect of multi –stages vapor compression refrigeration cycle using refrigerant R32 for Air- Conditioning unit

by Y Setiawan

Submission date: 18-Feb-2021 10:20AM (UTC+0700)

Submission ID: 1511992021

File name: 3._Effect_of_multi_stages_vapor_compression_konfren.pdf (308.05K)

Word count: 1942

Character count: 10372

PAPER • OPEN ACCESS

Effect of multi –stages vapor compression refrigeration cycle using refrigerant R32 for Air-Conditioning unit

To cite this article: H V Sihombing *et al* 2020 *IOP Conf. Ser.: Mater. Sci. Eng.* **725** 012017

View the [article online](#) for updates and enhancements.

Recent citations

- [A review of electrically driven dehumidification technology for air-conditioning systems](#)
Hongdou Liu *et al*

Effect of multi –stages vapor compression refrigeration cycle using refrigerant R32 for Air-Conditioning unit

H V Sihombing¹, H Ambarita^{1,*}, Waldemar Naibaho, and E Y Setiawan³

¹Sustainable Energy and Biomaterial Centre of Excellent, University of Sumatera Utara, Jl. Almamater Kampus USU, Medan 20155, Indonesia

²Mechanical Engineering Department, Universitas HKBP Nommensen, Medan

³Mechanical Engineering, National Institute of Technology Malang, Jl. Bendungan Sigura-gura No. 2 Malang 65145, Indonesia

*himsar@usu.ac.id

Abstract. Vapor compression cycle is mainly employed as a refrigeration cycle in the Air-Conditioning (AC) unit. In order to save energy, the Coefficient of Performance (COP) of the need to be improved. One of the potential solutions is to modify the system into the multi-stages vapor compression cycle. The present work deals with the investigation of single-stage and multi-stage vapor compression refrigeration cycle. A typical vapor compression cycle that is used in the AC unit is taken into consideration. The used refrigerants are difluoromethane R32. The analysis using the simulation process by utilizing software Aspen One. The performance parameters includes COP, the mass flow rate of the refrigerant and compressor power. It was shown that there exists a maximum COP for multi-stage. By taking these performance simulation results the multi-stage is the efficient method for the air conditioning system.

1. Introduction

The increase in population and industrialization had high an effect of greenhouse gasses emission. Air conditioning industry is growing rapidly throughout the Earth. The use of vapor compression cycle as air conditioning had impact of GHG emission. Air conditioning is maintained of temperature and humidity of a living for convenience, besides that, it is high consumption of energy. Most of the countries considered strategies for applied of vapor compression cycle with efficient and minimum impact for GHG emissions. There are several works related to increasing energy efficiency of a vapor compression cycle such as using heat recovery technique [1,2], multi-stages cycle, etc.

The present paper was focused in the compared a single-stage with a multi-stages vapor compression cycle. Adrian Mota-Babiloni et al. [3] analysis applied of refrigerant R32 can reduce GHG emissions. It value of GWP is 677, which is below the F-gas regulation limit in RAC equipment. Mahesh and Ravi [4] studied and compared by theoretically and experimentally refrigerant R22 and Refrigerant R290 for multistage vapor compression cycle. Nilesh, Dileep and Mani Sankar [5] studied performance of a two stage refrigeration cycle. This research used six common refrigerants, these are refrigerant R134a, R22 and R134a as synthetic refrigerants and propane, carbon dioxide and nitrous oxide as natural refrigerants. Jain et al. [6] showed that cascaded vapor compression-absorption system consist of a vapor compression refrigeration system coupled with a single effect vapor absorption refrigeration system. The effect of various operating parameters such as alternative refrigerant (R134a, R410A and R407C), superheating, sub-cooling, cooling capacity, inlet temperature and the product of effectiveness and heat capacitance of external fluids were investigated. Torella et



Content from this work may be used under the terms of the [Creative Commons Attribution 3.0 licence](https://creativecommons.org/licenses/by/3.0/). Any further distribution of this work must maintain attribution to the author(s) and the title of the work, journal citation and DOI.

Published under licence by IOP Publishing Ltd

al. [7] described a general methodology suitable for analyzing staged vapor compression refrigeration cycle by introducing two parameters related to the degree of sub-cooling and de-superheating parameters. Esfahani et al. [8] simulated a combined multi effect evaporation-absorption heat pump with vapor-compression refrigeration system using EES software. Manjili and Yavari [9] investigated a new two-stage multi intercooling transcritical CO₂ refrigeration cycle with injector-expansion device (MIERC). At this study used two intercoolers. It an increase COP 15.3% to 19.6 % than standard compression cycle. Messineo [10] analysis a cascade refrigeration system using as refrigerant carbon dioxide in low-temperature circuit and ammonia in high-temperature circuit. Results show that a carbon dioxide-ammonia cascade refrigeration system is an interesting alternative to R404A two-stage refrigeration system for low evaporating temperatures ($-30^{\circ}\text{C} \div -50^{\circ}\text{C}$).

Those studies showed that single-stages and multi-stages technology for vapor compression refrigeration cycle has come under scrutiny. The present work focuses on the investigation of compare single stages and multi stages vapor compression refrigeration cycle with new refrigerant in ASPEN PLUS. The used refrigerant here is 100 % Difluoromethane (refrigerant R32) which is a new refrigerant. The results for multi stage refrigeration system are compared with the single stage refrigeration system using the refrigerant R32. It should provide all useful results, such as pressures, heat duties, cycle COP, mass flow rates, either directly or readily available.

2. Solution Method

The governing equations of the systems are developed as follows. The power in the first (\dot{W}_{c1}) and second compressors (\dot{W}_{c2}) are calculated by

$$\dot{W}_{c1} = \dot{m}_1 (h_2 - h_1) \quad (1)$$

$$\dot{W}_{c2} = \dot{m}_2 (h_4 - h_3) \quad (2)$$

where h_1 , h_2 , h_3 , and h_4 are enthalpy of the refrigerant at the inlet and the exit of first compressor and at inlet and the exit of the second compressor, respectively. The total of the power to system is calculated by

$$\dot{W}_{tot} = \dot{W}_{c1} + \dot{W}_{c2} \quad (3)$$

The heat release by the system to ambient is given by equation (4).

$$Q_c = \dot{m}(h_4 - h_5) \quad (4)$$

where h_4 and h_5 are enthalpy of the refrigerant at the inlet and the exit of the condenser. Here \dot{m} is defined as the flow rate of the refrigerant entering the condenser. The heat absorbed by the refrigerant in the evaporator, is given by:

$$Q_e = \dot{m}(h_1 - h_g) \quad (5)$$

Refrigeration effect (ER) of the system is calculated by equation (6).

$$ER = h_1 - h_g \quad (6)$$

The coefficient of performance of the system (COP) is given by

$$COP = \frac{Q_e}{W_{tot}} \quad (7)$$

In the literature it is very limited equation can be used to estimate the optimum intermediate pressure(P_i) in terms of suction and discharge pressures. To the best knowledge of the author, only the below equation is proposed to estimate the optimum intermediate pressure [12].

$$P_i = \sqrt{P_e \times P_c} \quad (8)$$

Where P_e and P_c are the pressure of the evaporator and the condenser. A computer program has been developed to solve the above equations. The properties of the refrigerant is modeled using the data provided by American Society of Heating, Refrigeration, and Air Conditioning Engineers (ASHRAE).

3. Results and Discussions

3.1. Description of the setup

For the evaluation of concept, the entire process was simulated with the engineering software Aspen Plus. In the literature, the Refrigerant Properties equation of state (REFPROP in Aspen Plus) is commonly used for the calculation of the thermo physical properties in refrigerant simulation. The analysis is carried out for refrigerant R32. Operating conditions, here after named as case, are analyzed, the first case is at temperature evaporation of -10°C and temperature condensation of 40°C . For all cases the cooling load is assumed to be constant at 1000 Ton.

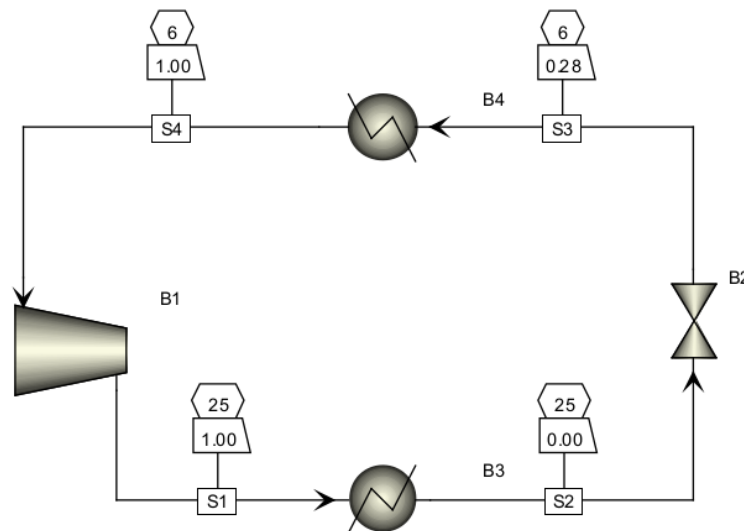

Figure 1. Single stage vapour compression cycle in Aspen-Plus

Figure 1 shows the single-stage vapor compression cycle in Aspen-Plus. A single-stage vapor compression system consists of a compressor, a condenser, an expansion valve, an evaporator while the figure 2. shows multi-stage vapor compression cycle in Aspen-Plus. A multi-stage vapor compression system consists of two compressors, a condenser, two expansion valve, a flash cooler, a mixing chamber, and an evaporator.

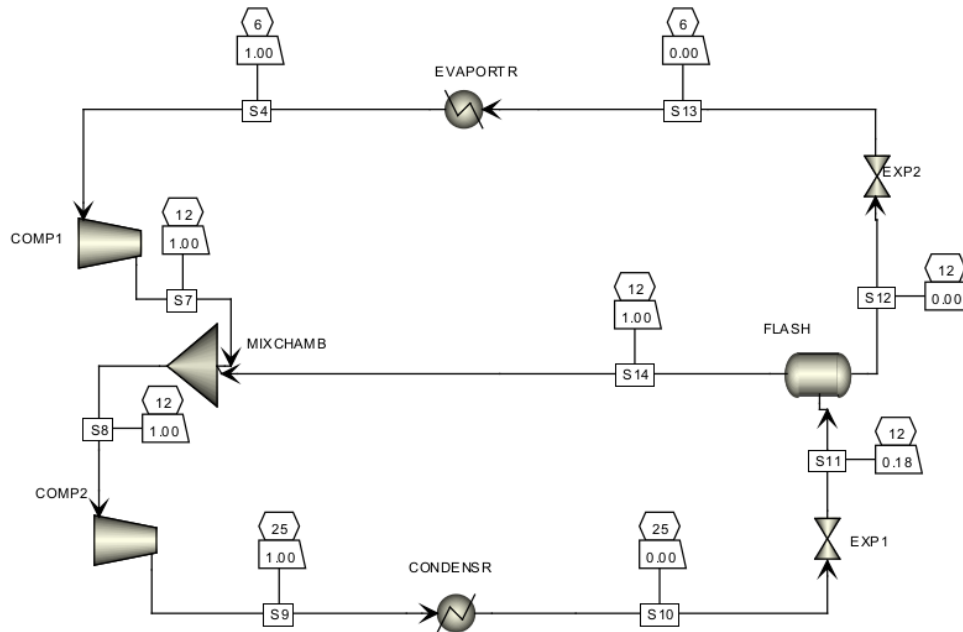

Figure 2. Multi stage vapour compression cycle in Aspen-Plus

3.2. Simulation result

The result the simulation are summarized in table 1. The total compressor power of single stage was $P_{tot}=1048$ kW, the two stage was $P_{tot}=955,7$ kW, which coefficient of performance of single stage was $COP = 3.35$, coefficient of performance of single stage was $COP = 3.67$

Table1. Result single and multi-stage of the Aspen Plus simulation

	Single stage		Multi stage	
			First stage	Second stage
Suction pressure (bar)	6	6	6	12
Discharge pressure (bar)	25	12	12	25
Compressor power (kW)	1048	403.6	403.6	552.1
Refrigerant composition (mass fraction)	100 % Difluoromethane			
Heat duty (cal/sec)	839224			839456
Total mass flow (kg/s)	14.8			12.11
Temperature before expansion valve (K)	25	40	40	13
Temperature after expansion valve (K)	-10	13	13	-10

In order to provide a convenient discussion, the value of COP was presented in Table 2. The data reveals that there is a discrepancy of the single stage with multi-stage. The results show that a significant decrease in the overall compression duty of the refrigeration cycle (8.8%) over the base case is obtained due to the reduction of the temperature lift (the temperature difference between the evaporator and condenser). This fact suggests that multi-stage using refrigerant R32 is effective than single stage

Table 2. Simulation results for refrigerant R32

Refrigerant	Coefficient of performance		Discrepancy [%]
	Single Stage	Multi Stage	
R32	3.35	3.67	8.8

4. Conclusions

The result of this work show Difluoromethane (refrigerant R32) effective used for multi-stage, multi-stage using refrigerant R32 gives the high coefficient of performance and decreases the work of compressor. The multi-stage using refrigerant R32 can improve 8.8 % performance of the refrigeration cycle than single-stage. The multi-stage concept promises efficiency vapor compression cycle systems.

References

- [1] Ambarita H, Nasution A H, Siahaan N M and Kawai H 2016 *Case Studies in Thermal Engineering* **8**, 105-114.
- [2] Ambarita H, Sihombing H.V. 2018. IOP Conf. Series: Journal of Physics: Conf. Series **978** 012098
- [3] Mota-Babiloni A, Navaro-Esbri J, Makhnatch P, Moles F. 2017. *Renewable and Sustainable Energy Reviews* **80** 1031-1042.
- [4] Kumar M, Vishwakarma R. P. 2015. *International Research Journal of Engineering and Technology (IRJET)*. P-ISSN:2395-0072.
- [5] Purohit N, Gupta D.K, Dasgupta M.S. 2016. *Energy Procedia* **90** 171-178.
- [6] Jain V, Kachhwaha S.S, Sachdeva G. 2013. *Energy Conversion* **75** 685-700.
- [7] Torella E, Larumbe J.A, Cabello R, Lopis R, Sanchez D. 2011. *Energy* **36** 4119-4124.
- [8] Esfahani I.J, Kang T.T, Yoo C. 2014. *Energy* **75** 312-326.
- [9] Manjili F.E, Yavari M.A. 2012. *Applied Thermal Engineering* **40** 202-209.
- [10] Messineo A. 2012. *Energy Procedia* **14** 56-65.
- [11] Khurmi R.S and Gupta J.K. 2006. *Refrigeration and Air Conditioning*. Ram Nagar, New Delhi.
- [12] Arora R C 2010 *Refrigeration and Air Conditioning*, PHI, New Delhi.

Effect of multi –stages vapor compression refrigeration cycle using refrigerant R32 for Air-Conditioning unit

ORIGINALITY REPORT

6%

SIMILARITY INDEX

5%

INTERNET SOURCES

0%

PUBLICATIONS

5%

STUDENT PAPERS

PRIMARY SOURCES

1

Submitted to Sriwijaya University

Student Paper

3%

2

www.aensiweb.net

Internet Source

2%

3

Submitted to Malaviya National Institute of Technology

Student Paper

2%

Exclude quotes On

Exclude matches < 2%

Exclude bibliography On