

The effect of stage number on the performance of a vapor compression refrigeration cycle using refrigerant R32

by E Y Setiawan E Y Setiawan

Submission date: 18-Feb-2021 12:52PM (UTC+0700)

Submission ID: 1512100566

File name: ge_number_on_the_performance_of_a_vapor_compression_konfren.pdf (398.83K)

Word count: 2570

Character count: 12891

PAPER • OPEN ACCESS

The effect of stage number on the performance of a vapor compression refrigeration cycle using refrigerant R32

To cite this article: A H Nasution *et al* 2020 *IOP Conf. Ser.: Mater. Sci. Eng.* **851** 012039

View the [article online](#) for updates and enhancements.

The effect of stage number on the performance of a vapor compression refrigeration cycle using refrigerant R32

A H Nasution¹, H Ambarita¹, H. V. Sihombing¹, E Y Setiawan², H. Kawai³

¹Sustainable Energy and Biomaterial Centre of Excellent, Universitas Sumatera Utara, Jl. Almamater Kampus USU, Medan 20155, Indonesia

²Mechanical Engineering, National Institute of Technology Malang, Jl. Bendungan Sigura-gura No. 2 Malang 65145, Indonesia

³Mechanical Engineering Department, Muroran Institute of Technology, 27-1 Mizumoto, Muroran 8585, Hokkaido, Japan

Email: himsar@usu.ac.id

Abstract. In the refrigerant cycle of Air-Conditioning (AC) unit the mainly used cycle is vapor compression cycle. The performance of the refrigerant, named as Coefficient of Performance (COP), need to be improved by using modification. The modification by using multi stage is one of the potential solutions. In the present study, the effect of number of stage to the performance will be explored. A simple vapor compression cycle that is typically used in the AC unit is taken into study. IN the cycle the refrigerant is difluoromethane R32. Three different stages are examined, they are single stage, two-stages, and three stages. The numerical analyses are carried out using commercial Aspen One software. The COP, mass flow rate of the refrigerant and compressor power will be discussed. The result shows that increasing the number of stages related to increasing the COP.

1. Introduction

Climate change becomes a hot issue today. One of that was the effect of greenhouse gas (GHG). now, most of the people in the world consent to reduce GHG. In order to get a convenient air in a room, Air Conditioning (AC) unit is usually used. The AC is employed to maintain the temperature and humidity of the room. Due to increasing standard living, the AC system consumes high electrical energy. Since the energy is mainly resulted from fossil fuel the air conditioning system has significant impact on GHGs emission. Strategies and innovation to improve the performance of vapor compression cycle are extremely needed. There are several studies related to enhance energy efficiency of a vapor compression cycle such as using new refrigerant, inter-stages cycle, internal heat exchanger, etc. [1, 2]

In a single stage system, as compression ratio in the system increase. A high value of temperature drastically reduces the efficiency of the compressor and causing an additional load on both the condenser and compressor. One of the effective solution to these problems a inter stage system is used [3]. In the present work, we focus on the cycle comparison when it is operated as single stage, two-stages, and three-stages. Sihombing, et al. [4] has reported their study on investigation the effect of the multi-stage vapor compression cycle. It was shown the difference between performance single-stage and two-stages, it increases by 8.8 % than single-stage. Shuxue and Guoyuan [5] investigated the



Content from this work may be used under the terms of the [Creative Commons Attribution 3.0 licence](https://creativecommons.org/licenses/by/3.0/). Any further distribution of this work must maintain attribution to the author(s) and the title of the work, journal citation and DOI.

cooling performance of R32 two-stage vapor compression system with vapor injection for domestic air-conditioner. The results show that, the refrigerant R32 vapor injection system has a significant performance enhancement for cooling performance. The Coefficient of Performance of the two stage compression system can improve 5-15 % and 10-12 %, respectively. Nilesh et al [6] studied influence of inter stage pressure on the performance of two-stage refrigeration cycle using inter cooler. There were 6 refrigerants examined. They are R22, R134a and R134a as synthetic refrigerants and propane, carbon dioxide and nitrous oxide as natural refrigerants.

Cordin et al. [7] review effect of multi-temperature as heat pump. Their work review the highlights of the major benefits and challenges of mechanically driven heat pumps and refrigeration systems. Using thermodynamics simulations, they reveal that multi-stages compressor cycle have the biggest COP. The Coefficient of Performance of the multi-stages compressor cycles is on average 8 % bigger than single stage. Mazzei and Palombo [8] analyzed the potential using of multi-stage integrated evaporative HVAC systems. Energy saving are evaluated hourly, with the mass flow rate of the supply air being kept constant. Murat [9] compare the single-stage and cascade vapour-compression refrigeration systems using R134a as the refrigerant. The results show that, for the cascade system provides a lower evaporating temperature, lower compressor discharge temperature, lower ratio of discharge to suction pressure and higher compressor volumetric efficiency. Liu et al. [10] investigated the two-stage compression heat pump water heater system. In this paper showed that the two-stage rotary compressor can provide much better energy performance than the conventional heat pump water heater.

Those studies showed that the vapor compression refrigeration cycle has come under scrutiny. Thus, many of innovations have been proposed by researchers to increase the COP. In this study we propose to explore the characteristics of the cycles with different number of stages. They are single-stage, two-stages, and three-stages vapor compression refrigeration cycle with refrigerant R32. The commercial simulation code of ASPEN PLUS is used to carry out the analysis. The results are expected to supply the necessary information to develop high efficient vapor compression cycle for AC.

2. Method of solution

In this section the governing equations are explained. For convenient only the two-stage cycle is explained. The rate of energy in the first compressor (\dot{W}_{c1}) and the rate of energy of the second compressors (\dot{W}_{c2}) are calculated, respectively, by

$$\dot{W}_{c1} = \dot{m}_1 (h_2 - h_1) \quad (1)$$

$$\dot{W}_{c2} = \dot{m}_2 (h_4 - h_3) \quad (2)$$

In those equations the parameter h_1 and h_2 are named as enthalpy of the refrigerant at the inlet and the exit of first compressor. Furthermore, the parameter h_3 and h_4 are the enthalpy at the inlet and the exit of the second compressor, respectively. The total of the energy rate to the cycle is given by

$$\dot{W}_{tot} = \dot{W}_{c1} + \dot{W}_{c2} \quad (3)$$

The rate of exhaust heat by the system to ambient can be calculated by equation (4).

$$Q_c = m(h_4 - h_5) \quad (4)$$

In this equation h_4 and h_5 are enthalpy of the refrigerant at the inlet and the exit of the condenser. Here m is defined as the flow rate of the refrigerant entering the condenser. The rate of heat drawn by evaporator from the system can be calculate by the below equation.

$$Q_e = m(h_1 - h_6) \quad (5)$$

The next parameter is the effect of refrigeration (ER) which can be calculated by equation (6).

$$ER = h_1 - h_6 \quad (6)$$

Finally, the coefficient of performance of the vapor compression cycle (COP) is calculated by

$$COP = \frac{Q_e}{W_{tot}} \quad (7)$$

3. Results and Discussions

3.1. Description of the system

In order to perform the simulation, the commercial software of ASPEN Plus is carried out. The thermophysical properties of the refrigerant at every condition is estimated using REFPROP which is embedded in the software. The used refrigerant here is R32. For all cases the evaporation temperature and condensation temperature is -10°C and 40°C , respectively. The cycle will be loaded with a cooling load of 1000 Ton of Refrigeration.

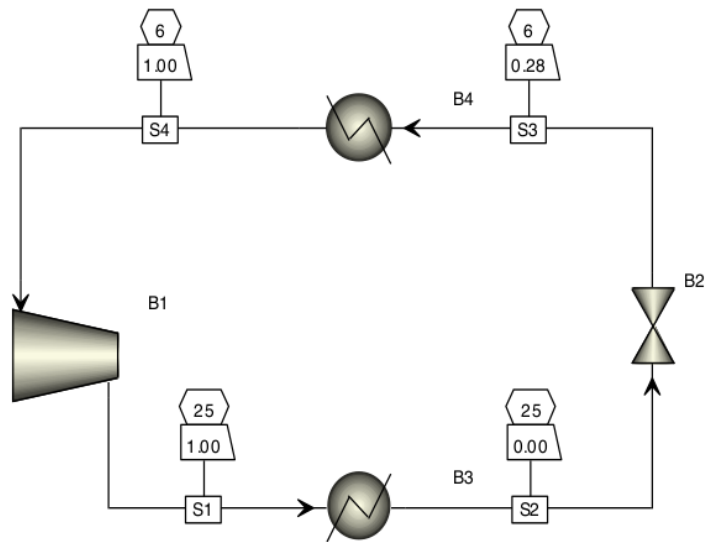

Figure 1. Single stage vapour compression cycle in Aspen-Plus

As a baseline as single stage vapour compression cycle is analysed. It consists an evaporator, a compressor, a condenser and an expansion valve. The schematic diagram of the single stage cycle in the Aspen is shown in Figure 1. In addition, the two-stage vapour compression refrigeration cycle is shown in Figure 2. The main components of the two-stage cycle are two compressors, a condenser, two expansion valves, and evaporator. The additional components in the two-cycles are a flash cooler and a mixing chamber. The position of all components in the cycle is shown in Figure 2. The liquid refrigerant from the condenser will be divided into liquid and vapour in the flash cooler. The liquid will be sent to the evaporator. On the other hand the vapour refrigerant will be sent to mixing chamber. The refrigerant from evaporator will compressed using first stage compressor. This refrigerant is in the vapour form and it will be collected with the refrigerant from the flash cooler in the mixing chamber. The total refrigerant from the mixing chamber will be compressed by the second stage compressor. This figure reveals that not of the refrigerant flow into the evaporator. This will affect the refrigerant effect of the system.

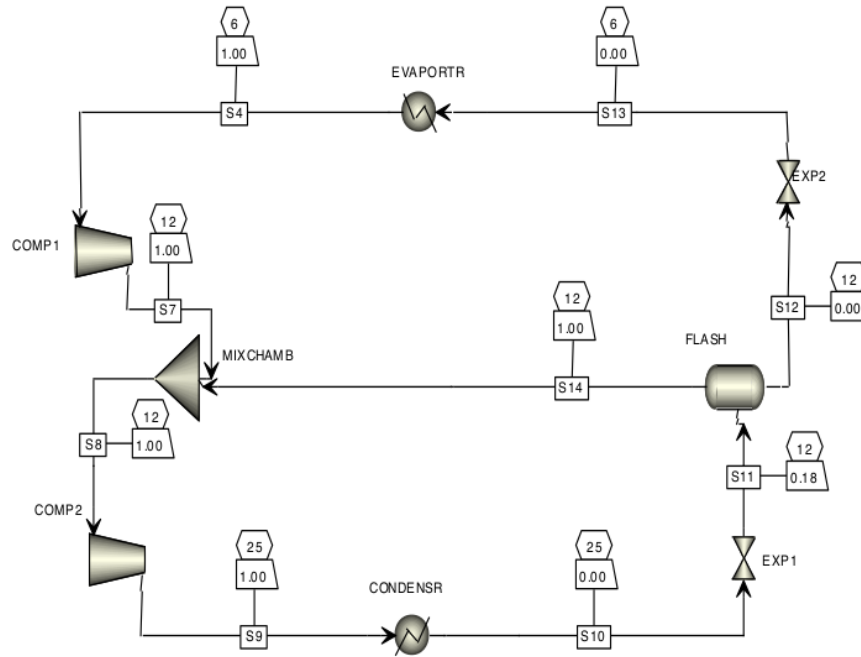

Figure 2. Two-stage vapour compression cycle in Aspen-Plus

Figure 3 shows the schematic diagram of the three-stage vapour compression cycle. It consists of three compressors, an evaporator, a condenser and two expansion valves. The additional components are two mixing chambers and two flash chamber. In the analysis the conservation of energy and conservation of mass will be employed in every condition.

3.2. Simulation result

The simulation for all cases have been carried out and the results are shown in Table 1. The parameter shown in the table are suction pressure, discharge pressure, compressor power, heat duty, the total mass flow rate, temperature before expansion and temperature after expansion. In the suction pressure, all of the lowest compressor of multi stages shows the similar value with the single stage. On the other hand, the discharge pressure of the upper compressor of the multi stages are similar. Only the intermediate pressure varies depend on the number of the stages.

The compressor power of the single stage is 1048 kW. In the two-stage cycle the power in the first and the second compressor are 403.6 kW and 552.1 kW, respectively. In total the total power in both compressors is 955.7 kW. This fact reveals that the total compressor power in the two-stage vapour compression cycle is lower than in the single stage. In the other word, the compressor power in the two-stage is lower 8.8% in comparison with single stage. Furthermore, for the three-stage cycle, the compressor power in the first, second and third compressors is 239 kW, 319 kW and 392 kW, respectively. In total the total power of compressor in the three-stage cycle is 950 kW. This fact reveals that the compressor power in the three-stage cycle is lower 9.35% in comparison with single cycle. In can be said that the compressor power decrease as number of cycle increase. The mass flow rate of the refrigerant in the cycle also decreases as number of cycle increases.

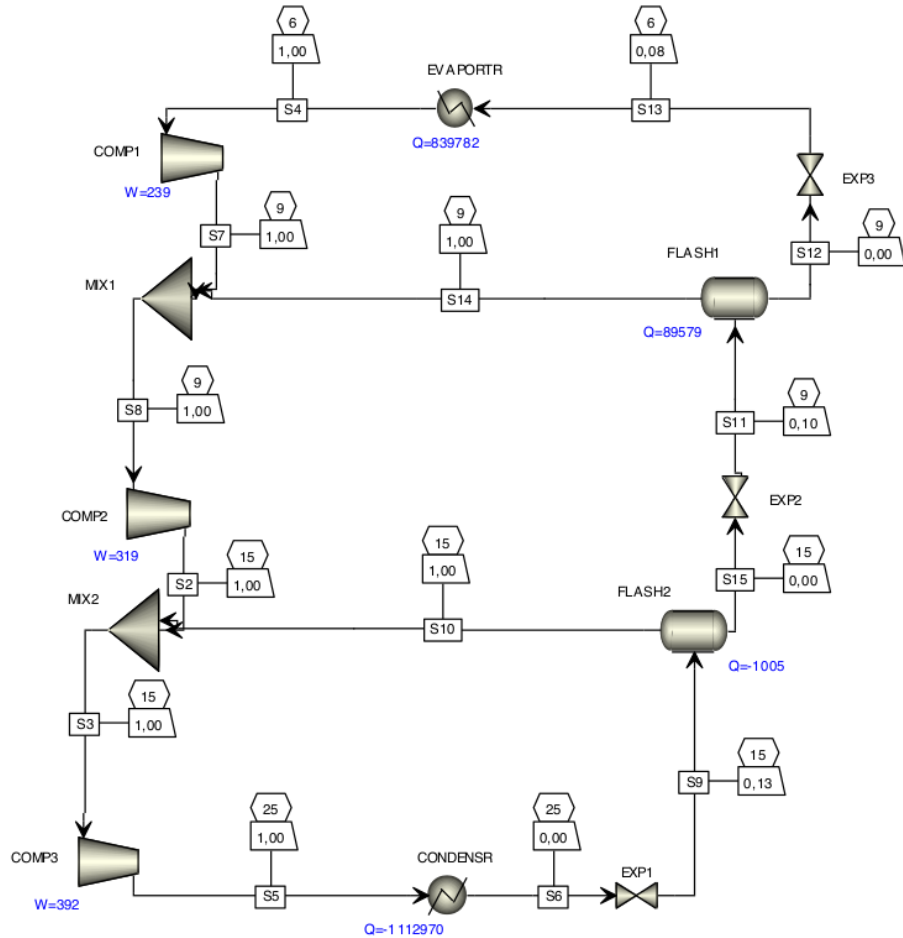

Figure 3. Three-stage vapour compression cycle in Aspen-Plus

Table 1. Result single-stage, two-stage and three-stage of the Aspen Plus simulation

	Single stage	Two-stages		Three-stages		
		First stage	Second stage	First stage	Second stage	Three stage
Suction pressure (bar)	6	6	12	6	9	15
Discharge pressure (bar)	25	12	25	9	15	25
Compressor power (kW)	1048	403.6	552.1	239	319	392
Refrigerant composition (mass fraction)	100 % Difluoromethane					
Heat duty (Cal/sec)	839224	839456		839782		
Total mass flowrate (kg/s)	14.8	12.11		11		
Temperature before expansion valve (K)	25	40	13	40	21	5

Temperature after expansion valve (K)	-10	13	-10	'21	5	-10
---------------------------------------	-----	----	-----	-----	---	-----

Finally the performance of the cycle is examined using the Coefficient of the Performance (COP). The COP for all stages are shown in Table 2. The COP for single stage, two-stage and three-stage are 3.35, 3.67, and 3.69, respectively. It was shown that the COP increases as number of stage increase. However, the difference from two-stage to three-stage is not as big as from single to two-stage. It is suggested that the two-stage is better than three-stage.

Table 2. Simulation results for refrigerant R32

Refrigerant	Coefficient of performance		
	Single Stage	Two Stage	Three Stage
R32	3.35	3.67	3.69

4. Conclusions

In this study the effect of number of stage in a vapor compression has been explored numerically using commercial code Aspen Plus. They are single-stage, two-stages, and three-stages vapor compression refrigeration cycle with refrigerant R32. The conclusion can be drawn here are as follows. The compressor power in the two-stage is lower 8.8% in comparison with single stage. The compressor power in the three-stage cycle is lower 9.35% in comparison with single cycle. It can be said that the compressor power decrease as number of cycle increase. The mass flow rate of the refrigerant in the cycle also decreases as number of cycle increases.

References

- [1] Ambarita H, Sihombing H. V. 2018. IOP Conf. Series: Journal of Physics: Conf. Series **978** 012098
- [2] Ambarita H. 2018. IOP Conf. Series: Earth and Environmental Science **126** 012018
- [3] Gupta V.K, Prasad M. 1983. International Journal of Refrigeration. Vol 6, Issue 2, 103-107.
- [4] Sihombing H. V, Ambarita H, Naibaho W, Setiawan E.Y. 2020. IOP. Conf. Series: Materials Science and Engineering **725** 012017.
- [5] Shuxue X, Guoyuan M. 2015. Energy and Building **93** 324-331.
- [6] Purohit N, Gupta D.K, Dasgupta M.S. 2016. Energy Procedia **90** 171-178.
- [7] Arpagaus C, Bless F, Schiffmann, Bertsch S.S. 2016. International Journal of Refrigeration **69** 437-465.
- [8] Mazzei P, Palombo A. 2015. International Journal of Ambient Energy, 18:1, 3-12.
- [9] Hosoz M. 2005. Turkish J. Eng. Env. Sci **29** 285-296
- [10] Liu F, Tan J, Xiong J. 2010. International Refrigeration and Air Conditioning Conference 2213
- [11] Khurmi R.S and Gupta J.K. 2006. Refrigeration and Air Conditioning. Ram Nagar, New Delhi.
- [12] Arora R C 2010 *Refrigeration and Air Conditioning*, PHI, New Delhi.

The effect of stage number on the performance of a vapor compression refrigeration cycle using refrigerant R32

ORIGINALITY REPORT

3%

SIMILARITY INDEX

2%

INTERNET SOURCES

0%

PUBLICATIONS

3%

STUDENT PAPERS

PRIMARY SOURCES

1

Submitted to University of Wales Swansea

Student Paper

3%

Exclude quotes On

Exclude matches < 2%

Exclude bibliography On