

Pallet Shortage

by Jabatan Fungsional

Submission date: 09-Apr-2021 06:44PM (UTC+0700)

Submission ID: 1554486964

File name: Article_Submit_Heliyon_3RPallet_4th_Revision.docx (1.71M)

Word count: 4553

Character count: 26584

A GREEN-BASED MANUFACTURING SYSTEM TO SOLVE PALLET SHORTAGE PROBLEMS

Fourry Handoko^{1*}, Catrien Paula², Sutanto Hidayat³, Endah Kusuma Rastini⁴,
Maranatha Wijayaningtyas⁵, Prima Vitasari⁶

^{1,2,6}Industrial Engineering, National Institute of Technology (ITN) Malang

⁴Mechanical Engineering, National Institute of Technology (ITN) Malang

^{3,5}Civil Engineering, National Institute of Technology (ITN) Malang

E-mails: *fourry.handoko@scholar.itn.ac.id,

Abstract: Pallets are crucial in the logistics infrastructure system of various industries and manufacturing companies. They are made of wood and used to store various large and heavy goods. However, pulp and paper manufacturing companies undergo material shortages to make wooden pallets. Therefore, this study aimed to apply the 3-R concept (Reduce, Reuse, Recycle) to deal with pallet shortages at the companies. After several experiments, the researcher developed three techniques based on the 3-R concept with the closed-loop system: (1) repairing and (2) reusing waste pallets from/to customers, (3) using Finger Glued-Laminate's products provided internally as raw materials for pallets; all three met several mandatory criteria of strength and design in a pallet. This research aimed to help companies make policies and strategies related to applying the 3-R concept to deal with pallet shortages. If the pallet quantity can meet the company's needs, it will improve the logistics process quality and deliver the products to consumers right on schedule.

Keywords: 3R, knowledge and technology, green approach, pallet shortage

1. Introduction

In the process of shipping/logistics, products are placed onto pallets promoting safe and efficient transporting, storing, and shipping with various conveyances (Waseem *et al.*, 2013; Bilbao *et al.*, 2011). The use of pallets is modern and global. Pallets are developed using a variety of materials, models, types, dimensions suitable for the product, conveyance, delivery, and storage destination; the common materials used are metal (considering the strength (Abdullah *et al.*, 2018)), plastic, paper, iron, and mostly wood (Singh, 2013). Pallets are used for three primary purposes: protecting products, streamlining storage, and streamlining product distribution (Karaçalı & Ulguel, 2014); safety is also an essential part of business regarding work performance (Handoko *et al.*, 2020).

The short and end-of-life cycle of wood pallets at final landfills affects the environment more severely than carbon dioxide emissions generated through tree logging, heat treatment, and fumigation (Bilbao *et al.*, 2011; Grande, 2008; Paula & Handoko, 2016; Kustamar *et al.*, 2018). Pallets are crucial in supporting the distribution and logistics process, so their shortage or unavailability will affect the manufacturing industry. In the case of Indonesian paper manufacturer companies, the government policy in limiting logging areas constricted by *Sistem Verifikasi Legalitas Kayu* or SVLK (Indonesian Timber Legality Assurance System) is an external threat to pallets

availability; it affects wood procurement as the raw material for making pallets and can cause delays in product delivery. An exporter company must also heed global warnings related to company management's green industry concept (Handoko *et al.*, 2014; 2016; 2018; Hidayat *et al.*, 2018). The company must meet consumers' demands, government regulations, and community needs to maintain its sustainability (Suarniki *et al.*, 2019).

Consequently, companies need to develop environmentally sound strategies and innovations in the pallet procurement unit to meet distribution needs. Knowledge and technology regarding the green approach will help companies to be aware of environmentally friendly manufacturing through assisting the organization in improving knowledge and technology capability (Wijayaningtyas *et al.*, 2019; 2020; Putri *et al.*, 2020; Hulukati *et al.*, 2020; Handoko *et al.*, 2014; 2016; 2017; 2019; Hidayat *et al.*, 2018). This research is a case study of pallet shortage in the pulp and paper industry in Indonesia. The 3R approach (Reduce, Reuse, and Recycle) is developable in minimizing the environmental impact of the production process. Pulp and paper manufacturing companies expect to overcome pallet shortages with used-pallets, wood waste, internal paper production processed with closed-loop system technique, and glued laminated-fing joint. This research aimed to build a strategy and innovation of pallet material using Reduce, Reuse, and Recycle (3R) concept in the pallet procurement unit to meet the production unit's needs and prevent product delivery delays.

2. Pallet Materials

A pallet is made from wood, plastic, metal, paper, and recycle materials; each has its advantages and disadvantages. In many cases, pallet choice depends on the type of product and supply chain configuration (Bilbao *et al.*, 2011). In the United States, 90% of these pallets are made of solid wood consisting of 22.4% hardwood, 7.1% softwood, and 10% various materials such as iron, aluminum, HDPE plastic, PVC, PC, plywood, cardboard, paper, and other composite materials; the main concern is the material's strength. These pallets have different characteristics depending on cost, durability, weight, sanitation, decontamination, load value, arrangement, and what is allowed in existing regulations (Bilbao *et al.*, 2011).

2.1 Types of Pallets

Selecting pallet type and pallet management depend on the supplier chain's product type and configuration (Bilbao *et al.*, 2011). In general, there are two types of pallets. The first type is stringer pallets (those having two-way or four-way entry); they use three or more parallel wooden frames; the top and bottom deck boards have the same spacing. The second type is block pallets (those having four-way entry); they use solid wood blocks at the bottom deck board to support the top deck board. A variety of pallets have been developed in the past few years, such as the single face, double face reversible, non-reversible double face, single-wing, double-wing, plug type, four-way notched stringers, and two-way pallets; all types of pallets are adjusted to the conveyance and the goods' capacity (NWPCA, 2014).

2.2 Reuse Pallet: Pallets Return

In a broad sense, packaging can be reused; it includes the pallets, shelves, containers, and wooden supports in which products can be moved efficiently and safely throughout the entire supply chain. Manufacturers and their vendors/consumers reuse packaging

by organizing a good supplier chain under strict delivery arrangements. The reusable packaging is made of durable materials such as iron, plastic, or wood. It is designed to withstand the logistics system's harsh treatment; it will offer a quick return on investment and lower cost for each shipment than a single-use packaging (Reusable Packaging Association, 2014).

2.3 Recycle Pallet: Finger Joint Pallet

Finger joint woods are made by interlocking pieces of wood glued/laminated at their ends, and the joint resembles interlocked fingers. These woods are made by removing defects reducing wood's strength and attaching the wood pieces; additionally, short woods that are finger-jointed can create the desired wood length. The finger joint wood can have desirable properties such as straightness, dimension, size stability, and strength; these can replace solid wood. It also offers unlimited length suitable for various applications, such as laminated wood glue, woodblock, and truss (Gong *et al.*, 2009).

2.4 'Reduce' Pallet: Paper Material

Paper pallets are commonly made by combining paper, paperboard, corrugated paperboard, honeycomb, and adhesive. These pallets offer lower support costs than conventional pallets while remaining light and robust (Harry, 1993). Paper pallets consist of several structures. A flat paper pallet is placed at the pallet's top; it comprises several layers and thick paperboard sheets. The sheet-shaped paper-based packaging can be thick and three-dimensional; it is laminated using glue or other materials. Additionally, putting two paper materials together into a single structure (one layer) requires quite a large force (Diana, 2015).

A corrugated pallet is made of kraft-paper layers forming a corrugated structure. Corrugated cardboard is one of the most popular packaging materials used for various products; the paper's quality is adjustable to the packaging's use and size, thickness, paperweight, layers of paper and the number of layers, also the groove-type of corrugated cartons used in various production (Bivainis and Jankauskas, 2015). Corrugated paper is a multi-layered structure (three or five layers) material separated by paper glue.

2.5 Principles and Benefits of 3R (Reduce, Reuse, and Recycle)

3R is a concept used for waste management to prevent pollution; developed into 5R, Replace and Replant are added to the 3R. The principle of 'Reduce' is optimized to minimize the use of goods or materials; the more materials are used; the more waste is produced. Suyoto (2008) explained that the 'Reduce' program includes: avoiding the use and purchase of products generating waste, buying goods in large packaging (instead of sachet packaging), buying goods with recyclable packaging (paper, leaves, and others), while 'Reuse' is optimized by selecting reusable goods.

Additionally, it is essential to avoid using disposable items to extend their usage time before becoming waste; the 'Reuse' program includes selecting products with recyclable packaging, using refillable products, and reducing disposable materials. Moreover, the 'Recycle' program is optimized by recycling goods that are no longer useful. Recently, many non-formal and home industries use waste to create their products, although not all goods can be recycled. The recycling program includes turning plastic waste into

souvenirs, processing organic waste into compost, and turning paper waste into painting or miniature toys.

3. Methodology

This research underwent two phases of fieldwork: (1) preliminary fieldwork and (2) fieldwork research and development, including the analysis and validity phase.

3.1 Preliminary fieldwork

The preliminary fieldwork was conducted to gain initial information about pallet shortage. In this phase, the researchers collected initial data and information regarding policy to deal with the problem by performing the following activities:

1. Discovering the phenomena regarding pallet shortage and its impact on environmental issues
2. Obtaining the preliminary information regarding the company business process where wood was chosen as the packaging material in the manufacturing process and collecting information regarding its impact on the environment
3. Conducting a literature review regarding the green industrial system, the environmental issues resulting from using pallets in the manufacturing process, alternative materials for pallets, palletizing, methods and techniques, including research instruments.

3.2 Fieldwork Research and Development

The researchers utilized the relevant literature review and the preliminary fieldwork result to create methods, techniques, and research instruments in conducting the full-range fieldwork research and development. This phase involved the following activities:

1. Collecting data from a pulp and paper industry organization;
2. Processing the data statistically and getting an overview of the conditions and production processes of the company;
3. Developing strategy and innovation for pallets by reusing pallets from consumers, utilizing wood waste and other waste, and utilizing internal products (paper) through the process of returning wood pallets, recycling of joints, and assembling paper pallets.

The 'Reduce' process included substituting materials from wood to paper using the glued-laminated technique. The 'Reuse' process involved returning pallets from consumers; the pallets were used for shipping finished products to the consumers. The researchers developed the closed-loop system method. The 'Recycle' process entailed recycling wood scraps and pieces from the pallet manufacturing process and taking workable wood pieces from pallets using the glued-laminated finger joint technique.

3.3 Analysis and Research Validity Phase

The fieldwork and development phase involved the following activities:

- a. 'Reduce' Pallet: Paper Pallets.

The researchers processed the data concerning the pallet's strength using a compression test (kgf). A pallet pressing test compared paper pallets with the main pallets (wooden) using the gap analysis method. The researchers conducted field tests with common pallet-treatment conditions that included

arranging the pallets in four stacks, with forklifts, conveyors, and trucks treatment.

b. *'Reuse' Pallet: Reusable Wooden Pallets*

The consumer data processed was based on the area and quantity of goods retrieval regarding using a pallet. The design system method could create a standard operation procedure (SOP).

c. *'Recycled' Pallet: Finger Joint Pallets*

The researchers processed the data about the pallet's strength using a compression test (kgf). A pressure test compared the finger joint pallets with the main pallets (wooden) using the gap analysis method. The researchers conducted field tests with common pallet-treatment conditions that included arranging the pallets in four stacks, with forklifts, conveyors, and trucks treatment.

d. *'Reduce, Reuse, Recycled' Pallet*

The researchers processed the data about the pallets' strategic value adjusted to the category and standard value of Green Industry Standard (SHI). Using the Value Stream Mapping method, the researchers compared the strategic value with the SHI value.

4. Research Results and Discussion

Pallets are part of the finished-product packaging at pulp and paper manufacturing companies. They are produced internally in the pallet unit and transferred to the production unit for the packaging process. Wooden pallets use solid softwood material in the form of boards and beams purchased from external vendors. Making wood pallets begins after the woods are approved (those without mould or are not weathered, without wood knots and insects inside). For export purposes, these pallets must undergo several treatments to meet the International Standards For Phytosanitary Measures # 15 (ISPM # 15) requirements, such as knot-free wood and bark, heat treatment, fumigation, ISPM stamp # 15.

Recently, using wood products and their by-products requires a certificate of *Sistem Verifikasi dan Legalitas Kayu* or SVLK (Indonesian Timber Legality Assurance System). It is a part of pest prevention and forest preservation even though it may require investment and long processing time. The pallets will be transferred to the production unit as per ordered specifications, including size, model, and type. Furthermore, the company covers local and export sales. The data obtained from the shipping report were mapped based on the distribution areas. Based on the results, the average pallet distribution-areas is as follows: Java covered 60% (55% Regular and 5% Non-regular), outside Java covered 10%, and export covered 30%. Correspondingly, the local area (Java - Regular Consumers) covered the largest consumers; the return and reuse project was implemented in this area.

4.1 The Closed Loop System Design in the Return Pallets.

The Closed Loop System was developed through:

1. Determining consumer areas with the most extensive pallet distribution. The previous data shows that the largest pallet distribution area (as the target area for return pallets) was the local and regular Javanese consumers.
2. Determining the pick-up path of return pallets. The determination of the pick-up path was done once per month or more if deemed necessary; the pick-up path

could be determined for one or more consumers, depending on the truckload and the path direction; the company used trucks returning from shipping finished goods, both to the same and different consumers that were still in the same direction.

3. Establishing Standard Operating Procedure (SOP)
Marketing: making standard bonuses, cutting payment systems, negotiating with consumers, and making a letter requesting return pallets and getting approval; Quality Assurance: making return pallets specifications and checking their quality and value; Warehouse: making the standard handling of pallets and socializing it to consumers; Transport: transporting/ arranging the trucks, path and pallet layout for the return pallet process.
4. Obtaining approval of return pallets from the consumers. The key to implementing pallet return and reuse was consumer approval. Request letters were distributed to all regular consumers in the Java area.

The most significant benefits of this closed-loop system were: wood material savings, process and energy savings in making pallets, reduced production cost savings, significantly reduced chemical emissions from fumigation, and significantly reduced logging. Differences in the design before and after pallet distribution are as follows: in the former, pallets were distributed from the company to consumers and reached the end-of-life (EOL). Most consumers hoarded the pallets and sold them to other parties as waste; in the latter (after research), pallets are distributed from the company to the consumers. These pallets will be sent back to the company and reused for shipping finished goods. To extend the pallets' life cycle, the company and consumers need to consider how they will handle them.

4.2 Recycle Pallet

Recycle Pallet Material. Recycled pallets are made of 3 materials:

(1) the remaining pieces of wood from making solid wood pallets, (2) damaged woods from the process of making pallets, the packaging process in the production unit, the warehousing and loading process, and (3) woods from damaged return pallets of consumers. The suitable woods are selected for recycling. The minimum length of the wood is 300mm with an adjusted width. The woods will undergo a cleaning process using shaving and saw machines.

The Mechanical Design of the Joint Finger Palette. The finger joint palette is made using the glued laminated - finger joint technique on the raw wood pieces; the production process starts with using a semi-automatic finger joint machine in the following stages: (1) four or more woods are stacked (or adjusted to the size of the table), (2) the woods are sawed using a machine and (measured) with finger geometry, (3) using the laminated technique, the woods are automatically jointed with glue; Finger joint wood is pressed to strengthen the glue, as drawn in Figure 1. Moreover, the finger joint palette assembly process is done similarly to a solid wood pallet: cutting the pieces following the size, assembling them based on the pallet model, and nailing them between the joints (Paula & Handoko, 2016).

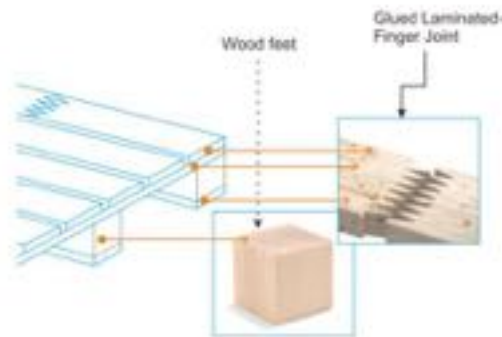

Figure 1. Finger Joint Palette

The most significant benefits in finger joint pallet are: wood material savings and significantly reduced logging.

4.3 'Reduce' Pallet

Paper Material Palette Substitution. To reduce using wood material in making pallets, the company substituted materials from wood to the industrial paper type and by-products, such as chipboard paper and spiral cores; they prioritized using the reject and remaining production materials.

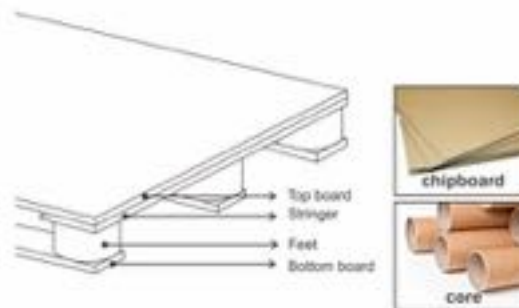

Figure 2. Paper Palette

Paper Palette Engineering Design. The company developed a flat pallet design with the following details, as drawn in Figure 2: the pallet used 9-layers chipboard paper on the deck (top board, stringer, bottom board) and the inter-layer lamination process used internally formulated paper glue; the bottom deck used a spiral core; the assembly process between parts used formulated internally paper glue; the pressing process was required to strengthen the lamination assembly process (Paula & Handoko, 2016).

4.4 Research Results Validity

System Design Method was used to test the 'reuse' pallet program validity, which was to build a new system, be accepted, and implement it with the Standard Operational Procedure (SOP) of handling return pallets from the consumers. It included consumer criteria and approval, return pallets using return conveyances, the return-path direction

of one or more consumers, pallet-values checking by the QC according to the work instructions and specifications, and the pallet-value recalculating in the next billing deduction.

Gap Analysis Method was used to test the 'reduce' and 'recycle' pallet programs validity. The researchers performed compressive testing (kgf); a solid wood pallet's compressive strength was measured using a finger joint and a paper pallet. The test results show that solid wood pallets' strength was not similar to finger joint and paper pallets; thus, the researchers conducted further analysis to determine the weight range of products packed at the company, finding that the weight of the product/load from the company ranges from 300-700kg. In the next step, the product weights were grouped and compared with the pallet's strength, explained as follows:

1. Wood Pallets: product load was greater than 600 kg
2. Finger Joint Palette: product load was less than and equal to 600 kg
3. Paper Pallets: product load was less than 400 kg

Value Stream Mapping Method was used to test the validity of the 'reduce', 'reuse', and 'recycle' pallet programs. The test was conducted using the Green Industry Standard (SHI) assessment criteria, focusing on aspects of the production process - material inputs. The indicators show that wood material can be substituted for paper material by 36% in paper pallet making from the 'reduce' pallet program. As per the SHI criteria assessment, the material substitution input was greater than 7.5%; the highest value (4) was fulfilled. Moreover, from the 'reuse' pallets program, the researchers found that return and recycling pallets and finger joint pallets could save wood use up to 21%. As per the SHI criteria assessment, the material's efficiency input was greater than 7.5%; the highest value (4) was fulfilled.

Product Financial Feasibility In the strategy and innovation of the 3R program, a financial feasibility analysis focused on calculating the cost of goods manufactured (COGM) using the variable cost method for paper pallets to meet the company needs; it was a major success in this research. The solid wood pallet's COGM was the benchmark, with average COGM was IDR 83,000 per wood pallet, while the paper pallet's price was IDR 63,060 per pallet. The price difference was IDR 19,940 per pallet. The paper-pallet raw material's price was calculated with the usual quality paper; thus, if they used low-quality paper (down-graded, rejected, broken), the price could be very far below IDR 63,060 per pallet. Additionally, Table 1 presents a comparison between material procurement and the process for obtaining strategic applications' approval:

Table 1. Potential Cost Comparison in Pallet

Item	Wood Pallet (solid)	Finger Joint Pallet	Paper Pallet
MATERIAL			
Acquisition	External / Vendor	Internal External - Consumer	100% internal, and downgraded, rejected, broken-products oriented
Availability	Limited	Limited	Unlimited
Cost	Uncontrolled	Controlled	Controlled
PRODUCTION COST			
Sorting Material	Performed	Performed	Not performed

Heat Treatment	Performed	Performed	Not performed
Fumigation	Performed	Performed	Not performed
ISPM stamp #15	Performed	Performed	Not performed

The results show that the development and innovation using the 3R approach offered a potential solution to overcome pallet shortage in the pulp and paper industry. With the weight of the product/load from the company ranges from 300-700kg, the results show that the 3R-based modified pallet could be the solution to the pallet shortage in which: (1) the wood pallets could be used for product load greater than 600 kg, (2) the finger joint pallet could be used for product load less than or equal to 600 kg, and (3) the paper pallets could be used for product load less than 400 kg.

5. Conclusion

Creating strategy and innovation with Reduce, Reuse, and Recycle (3R) solved the problem of wood shortage (the material for making pallets) at the pulp and paper manufacturing company; the program was applied to meet the company's need for pallets and create new opportunities. The *Sistem Verifikasi dan Legalitas Kayu* or SVLK (Indonesian Timber Legality Assurance System) led to the problem; it is a mandatory government program supporting ecosystem conservation and the country's image intended to make the products accepted in the international market. 'Reduce' pallets were made by substituting wood to paper in the form of chipboard and core. The paper was laminated and assembled into parts of the pallet deck using the glued laminated technique, while the core was used as the pallet bottom deck. Paper pallets could carry less than 400 kg of transport loads; consequently, they can meet the company's needs unless there is a transport load greater than or equal to 500 kg. 'Recycle' pallets were made by utilizing wood scraps/waste/ damaged woods. The woods were jointed and assembled into a joint finger pallet using the glued laminated - finger joint technique; this pallet can carry less than 600 kg of transport loads. 'Reuse' pallets were made by utilizing used pallets from consumers. With a closed-loop system, finished goods with wood pallets (solid) were sent to consumers, and the pallets were piled up at the consumer's place for later return (to the producer) and reused; this pallet can carry greater than 600 kg of transport loads. This green approach overcame the pallet shortage of the pulp and paper manufacturing industry.

References

- Abdullah, Z., Ting, H.Y., Ali, M.A.M., Ghazaly, M.M., Handoko, F. (2018) "The effect of layer thickness and raster angles on tensile strength and flexural strength for fused deposition modelling (FDM) parts" *Journal of Advanced Manufacturing Technology*, 12(Specialissue4), pp. 147-158
- A.M. Bilbao, A.L. Carrano, M. Hewitt, and B.K. Thorn (2011). On the environmental impacts of pallet management operations. *Management Research Review*.
- A.Waseem, A.Nawaz, N. Munir, B. Islam, and S., Noor (2013). Comparative Analysis of different Materials for Pallet Design using ANSYS. *IJME-IJENS*, Vol.13.

- Diana Twede (2015). History of Packaging In M. Tadajewski & D. G. Brian Jones, *The Routledge Companion to Marketing History*, (pp. 115-129). Routledge, Taylor & Francis Group.
- Grande, J. A. (2008). Plastic pallets gain ground in an eco-conscious world, *Plastics Technology*.
- Handoko, F., Alan, S., and Burvill, C. (2014). The Role of Government, Universities, and Business in Advancing Technology for SMEs' innovation. *Journal of Chinese Economic and Business Studies*. Vol 12, No. 2. pp. 171.
- Handoko, F., Nursanti, E., Harmanto, D., and Sutriyono (2016). The role of tacit and codified knowledge within technology transfer program on technology adaptation. *ARNP Journal of Engineering and Applied Sciences*, Vol.11, No. 8.
- Handoko, F. (2017). Constructing Knowledge and Technology Transfer Model for SMEs Technology Development in Emerging Economies. *International Journal of Pedagogy and Teacher Education*. Vol 1, No. 2. pp. 93
- Handoko, F., Nursanti, E., Gatot, Tjahjadi, M.E., Hutabarat, J., Mulyadi, L., and Kustamar (2018). Green Industrial System in Indonesia, *MATEC Web Conf.*, 164 (2018) 01010, DOI: <https://doi.org/10.1051/mateconf/201816401010>
- Handoko, F., Vitasari, P., Hidayat, S., Tjahjadi, M.E. (2019). Technology transfer program for SMEs in Indonesia, *Journal of Physics: Conference Series*, 1375(1), 012053
- Handoko, F., Wijayaningtyas, M., Imam H. A. Kusuma, I H A., Hidayat, S., Ismail, A., Abdullah, Z. (2020). The Occupational Health and Safety Effects on Road Construction Worker Performance, *Civil Engineering and Architecture*, Vol. 8, No. 5, pp. 750 - 759. DOI: 10.13189/cea.2020.080502
- Harry C. Juvik-Woods Damage Prevention Products, Inc. Priority 1990-12-26 • Filed 1992-06-26 • Granted 1993-07-27 • Published 1993-07-27. WO EP US CN AU CA [US5230291A](https://patents.google.com/patent/US5230291A)
- Hidayat, S., Handoko, F., Tjahjadi, M.E., and Vitasari, P. (2018). The triple helix and technology capability and competitiveness of SMEs in developing economy. *International Journal of Civil Engineering and Technology*, Vol. 9, No.13, pp 366-378. <http://www.iaeme.com/ijciet/issues.asp?JType=IJCIET&VType=9&IType=13>
- Hulukati, S. A., Sholihah, Q., and Marjono (2020). The potential of utilizing solar power plants in the city of Gorontalo in supporting a green city. *International Journal of Innovation, Creativity and Change*, Vol. 11 No. 5, 49-58.
- Karaçalı, Ö and Ulguel, A. (2014). Finite Element Analysis of Pallet-Nail Materials Used in Pallet Joint Design for Material Handling Works. *Acta Physica Polonica A*. 125. 183-185. 10.12693/APhysPolA.125.183.
- Kustamar, Handoko, F., Soetedjo, A. (2018). Flood control strategy in Sampang City, East Java, Indonesia, *International Journal of GEOMATE*, 15(52), pp. 62-67
- M Gong, Stephen Delahunty and Y.H.Chui (2009). Development of a Material-efficient Finger-Joint Profile for Structural Finger-Joint Lumber, Research Report, University of New Brunswick.
- National Wooden Pallet & Container Association. Pallet Supply Chain [Online]. Available: <http://www.palletcentral.com>, December, 2014
- Paula, C., and Handoko, F. (2016). Implementasi Reduce, Reuse, Recycle (3R) untuk Memenuhi Kebutuhan Palet pada PT. X. (The Implementation of Reduce, Reuse, Recycle (3R) to Meet Pallets Demand in PT.X) *Prosiding SENIATI*, 0(Book-1).

- Putri, D.S.A., Abidin, Z., Asnawati and Lukiyanto, K. (2020). The effects of green products, environmental attitudes and social media marketing on willingness to buy (empirical study on stainless steel straws in Balikpapan). *International Journal of Innovation, Creativity and Change*, Vol. 12 No. 12, 675-695.
- R.R.Singh (2013). Pallets, An efficient and safe way of material handling. Bureau of Indian Standard.
- Reusable Packaging Association. [online]. Available <http://www.resusable.org>, March, 2014.
- Suarniki, N. N., Wijayaningtyas, M., Lukiyanto, K., Kusuma, Y. B., and Farid Afandi, M. (2019). Community as a driver of SMEs growth in Indonesia. *International Journal of Scientific and Technology Research*, 8(10), 2740-2744. <http://www.ijstr.org/finalprint/oct2019/Community-As-A-Driver-Of-Smes-Growth-In-Indonesia.pdf>
- Suyoto, B. (2008). Fenomena Gerakan Mengolah Sampah, (Phenomena of Waste Managing Movement) Jakarta. PT. Prima Infosarana Media.
- V. Bivainis., V Jankauskas (2015). Impact of Corrugated Paperboard Structure on Puncture Resistance. *Materials Science (Medžiagotyra)*. Vol. 21, No. 1.
- Wijayaningtyas, M., Handoko, F., and Hidayat, S. (2019). The millennials' perceived behavioural control on an eco-friendly house purchase intention. *Journal of Physics: Conference Series*, Annual Conference of Science and Technology, Vol. 1375, 1, 012060, IOP Publishing.
- Wijayaningtyas, M., Hidayat, S., Nainggolan, T A., Handoko, F., Lukiyanto, K., Ismail, A. (2020). Energy Efficiency of Eco-Friendly Home: Users' Perception, *E3S Web of Conferences* 188, 00019. <https://doi.org/10.1051/e3sconf/202018800019>

Pallet Shortage

ORIGINALITY REPORT

3%

SIMILARITY INDEX

3%

INTERNET SOURCES

2%

PUBLICATIONS

1%

STUDENT PAPERS

PRIMARY SOURCES

1

eur-lex.europa.eu

Internet Source

1%

2

Submitted to Institut Teknologi Nasional Malang

Student Paper

1%

3

arts.studenttheses.ub.rug.nl

Internet Source

<1%

4

en.wikipedia.org

Internet Source

<1%

5

www.medexplorer.com

Internet Source

<1%

6

"International Conference on Intelligent Data Communication Technologies and Internet of Things (ICICI) 2018", Springer Science and Business Media LLC, 2019

Publication

<1%

7

jurnal.uns.ac.id

Internet Source

<1%

8

islamicmarkets.com

Internet Source

<1%

9

meridian.allenpress.com

Internet Source

<1%

10

www.emeraldinsight.com

Internet Source

<1%

Exclude quotes Off

Exclude matches Off

Exclude bibliography On